

Corporate Social Responsibility: The New Engine of Entrepreneurship Development

Bhupal Bikram Kathayat*

Abstract

As modern societies evolve, entrepreneurial sustainability becomes increasingly relevant and applicable across developed and developing countries worldwide. The issue of corporate social responsibility (CSR) in business has grown significantly, and it has been identified as a strategic weapon for entrepreneurship growth today. Thus, the present study attempted to examine CSR's influence on entrepreneurship development. Carroll's four social responsibilities in this study can be considered as CSR: economic, legal, ethical, and philanthropic. The study followed a positivist research paradigm, deductive reasoning, a causal-comparative research method, and convenience sampling techniques for its procedural operations. The study's target population was the total number of registered small and medium-sized enterprises (SMEs) in Dailekh District. The study incorporated 465 business owners as the sample size. The structured survey questionnaire was used to collect the primary data. The data were analyzed using descriptive and inferential statistics like percentages, frequency, and structural equation modeling. In order to analyze the data, SPSS 20 and AMOS 23 were used. The results of the study demonstrated that there is a significant positive impact of CSR on entrepreneurship development. Therefore, the concerned stakeholders should consider preserving CSR in their businesses. In addition, the study's results will be a source of information for stakeholders like entrepreneurs, customers, researchers, and academicians.

Keywords: Small and medium-sized enterprises, economic responsibility, legal responsibility, ethical responsibility, philanthropic responsibility

Introduction

In the recent period, the issue of corporate social responsibility (CSR) has been growing due to the changing perspectives of distinct stakeholders. Bales et al. (2021) defined CSR as an organizational commitment to acting ethically and responsibly

* Kathayat (MPhil) is an Assistant Professor, Graduate School of Management, Mid-West University.
Email: bnb.kathayat@gmail.com/bhupal.kathayat@mu.edu.np

toward their stakeholders, including customers, employees, shareholders, suppliers, and the wider community. Moreover, CSR has emerged as a new engine of entrepreneurial development as businesses increasingly recognize the importance of integrating social and environmental considerations into their operations today (Wu et al., 2021). CSR is based on the idea that businesses are responsible for creating value for their shareholders and society (Dathe et al., 2022; Streimikiene & Ahmed, 2021; Lu et al., 2020; Amaeshi et al., 2013). Despite that, CSR involves adopting sustainable practices that promote economic, social, and environmental well-being while ensuring the company remains profitable and competitive (Haldar, 2021; Mazzei et al., 2016). There are several reasons why CSR has become an essential driver of entrepreneurial development, including changing customer psychology, government rules and regulations, and the increasing rate of globalization and competition (Yu et al., 2017; Amran et al., 2014; Claydon, 2011; Smith & Langford, 2009). Moreover, the social responsibilities of businesses can be classified into four major categories: economic, legal, ethical, and philanthropic (Carroll, 2016).

On the other hand, entrepreneurship development refers to creating new businesses or expanding existing ones (Leonidou et al., 2020; Ahmed & Nwankwo, 2013). Likewise, entrepreneurship is an essential driver of economic growth and job creation, particularly in developing countries where small and medium-sized enterprises (SMEs) are the primary source of employment (Manzoor et al., 2021; Gherghina et al., 2020). The integration of CSR into entrepreneurship development has several benefits that consist of building trust and credibility (Gielnik et al., 2012), addressing social and environmental challenges (Lee et al., 2016), and attracting and retaining talented employees who are committed to social and environmental causes (Jindal & Bhardwaj, 2016; Ibrahim et al., 2012). For instance, Joshi (2019) and Valliere and Peterson (2009) discussed how CSR initiatives can create opportunities for entrepreneurship by identifying unmet social and environmental needs that

entrepreneurs can address through their businesses. In addition, Branco and Rodrigues (2008) found that companies that engaged in CSR activities had higher levels of customer loyalty and employee satisfaction, which can contribute to the success of entrepreneurial ventures.

An overall framework for promoting CSR in entrepreneurial development is a critical issue. Even though businesses have various strategies for incorporating CSR into their operations, the effectiveness of these strategies often needs to be clarified, leading to inconsistencies in the implementation of CSR (Ali et al., 2020; Bocquet et al., 2019); this can create challenges in achieving sustainable development goals and hamper entrepreneurship growth (Martinez-Conesa et al., 2017; Zhang & Cueto, 2017). As a result, some businesses have successfully integrated CSR into their operations and strategies, while others in developing countries like Nepal have yet to succeed. This knowledge gap represents a significant challenge for researchers, policymakers, and marketers promoting entrepreneurship development through CSR. Therefore, the study's problem statement is: What are the most influential corporate social responsibilities for entrepreneurship development, and how can SMEs be encouraged to adopt these responsibilities sustainably? However, the present study aims to examine the impact of CSR on entrepreneurship development in the context of SMEs in Dailekh District, Karnali Province, Nepal.

Literature Review

This section incorporated theoretical and empirical reviews of previous studies to justify the ground reality of CSR and entrepreneurship development worldwide. Windsor (2001) stated that CSR refers to a company's voluntary actions to address social and environmental issues beyond its legal obligations and to create a positive impact on society. Furthermore, CSR serves as a new engine of entrepreneurial development to improve the company's reputation, build customer trust, and enhance

customer loyalty, leading to increased profitability and sustainability (Prahalad, 2014; Perrini et al., 2007; McWilliams et al., 2006). Furthermore, CSR can contribute to economic growth by stimulating innovation and fostering entrepreneurship (Greening & Turban, 2000; Carroll, 1991). However, CSR initiatives such as collaboration, knowledge-sharing, social involvement, and environmental protection assure entrepreneurial growth and promotion (Anderson et al., 2001; Tietenberg & Folmer, 2000; Cropper & Oates, 1992). The present study addressed the relationship between four significant corporate social responsibilities and entrepreneurial development. In order to create a conceptual framework and a working hypothesis for the study, Carroll's four social responsibilities of business-related theoretical and empirical studies were reviewed. In this section, the researcher attempted to design the working hypotheses with the help of previous studies' outcomes.

Economic responsibility and entrepreneurship development

From the business perspective, economic responsibility can be defined as the need for individuals and organizations to act financially to safeguard the stakeholders' common interests. On the other hand, entrepreneurship is creating and managing a new business venture (Dioneo-Adetayo, 2006; Lordkipanidze et al., 2005). For entrepreneurship to thrive, economic responsibility must be upheld by all stakeholders involved (Batchenko & Dielini, 2017; Azmat & Samaratunge, 2009). When entrepreneurs are economically responsible, they not only create successful businesses but also contribute positively to society (Shinkafi & Ali, 2018; Yaluner et al., 2019). Moreover, the economic responsibility of businesses can create jobs, pay fair wages, follow safety regulations, and invest in sustainable practices for society (Ateljevic & Trivic, 2016; Miragaia et al., 2015). On the contrary, the negative impacts of economic responsibility on entrepreneurship growth include a greater focus on short-term gains and reducing financial risk over pursuing growth opportunities, cost of

renewal and tax regulations (Rahdari et al., 2016; Nguyen & Mort, 2016). The economic responsibilities of a business include increasing earnings per share, being dedicated to profitability, maintaining a strong competitive position, increasing operating efficiency, and establishing consistent growth (Carroll, 1991). Thus, the present researcher attempted to develop a working hypothesis based on the results drawn from the previous studies such as:

H1: Economic responsibility has a significant positive impact on entrepreneurship development

Legal responsibility and entrepreneurship development

Legal responsibility is an essential aspect of entrepreneurship development as it helps to ensure that entrepreneurs operate within the bounds of the law and do not engage in unethical or illegal activities (Raimi et al., 2015; Sekliuckiene & Kisielius, 2015). Entrepreneurs have a legal responsibility to comply with local, state, and federal laws and regulations related to their business operations, such as taxation, labor, environmental and intellectual property laws (Ramasastry, 2015; Grbac & Loncaric, 2009). By taking legal responsibility seriously, entrepreneurs can build a reputation for being trustworthy and responsible, which can help attract customers, investors, and employees (Carroll, 2015; Rahim, 2013). Moreover, legal responsibility covers a broad range of areas, including health and safety, consumer protection, business licenses and permits, and all relevant safety standards of the products (Fassin & Buelens, 2011; Meyer & Crane, 2010; Carroll, 1999). However, the legal responsibility of business consists of obeying government laws, complying with rules and regulations, being a corporate citizen, fulfilling legal obligations, and maintaining legal standards on products (Carroll, 1991). Therefore, entrepreneurs need to know their legal obligations when starting and running a business. Based on the conclusions

achieved from the earlier studies, the current researcher tried to formulate a working hypothesis such as:

H2: Legal responsibility has a significant positive impact on entrepreneurship development

Ethical responsibility and entrepreneurship development

Ethics are the principles of right and wrong that guide behaviour (Murphy, 2009; Beauchamp et al., 2004). Besides that, *ethical responsibility* refers to the obligation of individuals and organizations to act in a morally responsible manner toward others and society (Hassan, 2016; Bird, 2009; Carroll, 2000). In this context, ethical responsibility is critical because it ensures that entrepreneurs are accountable for their actions and mindful of their decisions' impact on stakeholders (Harrison et al., 2020; Schwartz, 2011; Ardichvili et al., 2009). By adhering to ethical principles, entrepreneurs can create a sustainable and responsible business that contributes to the well-being of society (Vallaster et al., 2019; Baden, 2014). Conversely, ethical responsibility can help entrepreneurs build trust, attract talent, differentiate themselves in the market, achieve long-term success, and mitigate risk (Chell et al., 2016; Morris et al., 2002). According to Carroll (1991), ethical responsibility consists of maintaining socio-cultural norms, recognizing evolving moral standards, preventing ethical culture in the workplace, ensuring corporate citizenship, establishing corporate compliance, and minimizing business malpractices. Thus, the present researcher tried to build an operational hypothesis based on the results drawn from the previous studies such as:

H3: Ethical responsibility has a significant positive impact on entrepreneurship development

Philanthropic responsibility and entrepreneurship development

Philanthropic responsibility refers to the moral obligation of individuals and organizations to engage in charitable activities and contribute to social welfare (Iwannanda & Adiputra, 2017). Philanthropy plays a crucial role in promoting and supporting entrepreneurship development, and entrepreneurs can create a positive social impact through their businesses and philanthropic efforts (Liu et al., 2017; Halme & Laurila, 2009). Philanthropic responsibility can positively impact entrepreneurship development by providing access to capital, supporting innovation, providing mentorship and support, facilitating collaboration, and promoting social impact (Wu et al., 2021; Das et al., 2020; Sigdel & Amponstira, 2020; Amaeshi et al., 2016; Mehta & Sharma, 2016; Tewari & Pathak, 2014). According to Carroll (1991), the philanthropic responsibility of business consists of performing works related to charity and donation, involving in volunteering activities, providing assistance to educational and health institutions, and improving the quality of life in society. However, based on the conclusions accomplished from the earlier studies, the current researcher tried to formulate a working hypothesis such as:

H4: Philanthropic responsibility has a significant positive impact on entrepreneurship development

Research Methodology

The use of quantitative methods and deductive reasoning in research involves formulating hypotheses based on existing theories, collecting numerical data, conducting statistical analyses, and drawing objective conclusions (Brayman, 2004; Evans & Over, 1997). This approach contributes to the development of empirical evidence, enhances the reliability and validity of research findings, and supports the advancement of knowledge in respective field of study (Tashakkori & Creswell,

2007). The theory employed in the study serves as the overall framework for the investigation, organizing models for the research questions or hypotheses and methods for data collection. Additionally, an increasingly important trend in behavioral and social sciences the present researcher focuses to adapt established theories to examine the cause-effect relationship between theoretical assumptions and estimated outcomes in the CSR and entrepreneurship development. As a consequence, this study was conducted to examine the impact of Carroll's four corporate social responsibilities on entrepreneurial development. However, the study followed a positivist research paradigm, deductive reasoning, quantitative method, causal-comparative research design, and convenience sampling techniques for its processing.

Furthermore, the study's target population was the number of registered small and medium-sized enterprises (SMEs) in the Dailekh District. The study incorporated 465 business owners as a sample size. The survey was conducted during June 2022–July 2022 period. The structured survey questionnaire was used to collect the primary data. The data were analyzed using descriptive and inferential statistics like percentages, frequency, and structural equation modeling. In order to analyze the data, SPSS 20 and AMOS 22 were used. According to Sekaran and Bougie (2016), the questionnaire is supported to guide the flow of the information-gathering process. For this, the researcher prepared two parts of the questionnaire to collect authentic information from the target population and the sample. Part, one consists of demographic responses, and part two includes study variable-related questions. In the second part, five-point Likert questions were designed for five variables with 27 items or statements. On the other hand, different kinds of validity and reliability (discriminant validity, convergent validity, and composite reliability) tests were measured before conducting structural equation modeling (SEM) and testing the study's hypotheses.

Results/Findings

In this section, the researcher attempts to present and discuss the findings captured during the study. The respondents' responses were analyzed using descriptive and inferential statistics with the help of IBM SPSS 20 and Amos 22. This chapter is divided into two separate sections. The respondents' demographic responses are analyzed in the first section, including age, gender, education, nature of business, and satisfaction. In the second section, inferential statistics related to constructs or variables, such as principal component analysis (PCA), confirmatory factor analysis (CFA), structural equation modeling (SEM), and hypothesis tests, were primarily covered. The study concluded by highlighting the most important or noteworthy discoveries made due to the analysis and results.

Analysis of demographic responses

In this section, the researcher used descriptive statistics to analyze the demographic responses of the respondents. Age, gender, education, nature of business, and satisfaction with the current business were included as demographic responses. The demographic responses were presented and analyzed with the help of Table 1.

Table 1
Analysis of Demographic Responses

Demographic Variable	Category	Frequency (f)	Percentage (%)
Age	Less than 20 years	28	6.0
	20-30 years	114	24.5
	30-40 years	160	34.4
	40-50 years	123	26.5
	50 and above	40	8.6
Gender	Male	261	56.1
	Female	204	43.9
Education	Primary	48	10.4
	Secondary	228	49.0
	Undergraduate	161	34.6
	Graduate and above	28	6.0
Nature of Business	Manufacturing	143	30.8
	Trading	102	21.9
	Service	171	36.8
	Construction	49	10.5
Satisfaction	Yes	412	88.6
	No	53	11.4

Note: Sample size (N) = 465

Table 1 shows the results of the respondents' demographic responses. Out of the total respondents, 34.4 percent were in the 30–40 age group and 26.5 percent were in the 40–50 age group. In the same line, 24.5 percent of the respondents were 20–30, and 8.6 percent were between the 50 and above age group. Similarly, 6.0 percent were of less than 20 years age group. On the other hand, out of the total respondents, 56.1 percent were male, and 43.9 percent were female respondents who participated in this study. Similarly, regarding educational status, out of all respondents, 49.0 percent represented the secondary level, and 34.6 percent represented the undergraduate level. Besides that, 10.4 percent of respondents were from the primary level, and 6.0 percent were graduates and above. Moreover, out of the total respondents, 36.8 percent were service-oriented, and 30.8 percent represented manufacturing-oriented businesses. Similarly, 21.9 percent were from trading, and 10.5 percent were from construction-oriented businesses. On the other hand, out of the total respondents, 88.6 percent answered that they are satisfied with their current business, and the rest, 11.4 percent are not satisfied.

Analysis of variables related responses

In this section, the researcher applied inferential statistics to analyze the study variables and related responses of the informants. This section can also be classified into three parts: principal component analysis (PCA), confirmatory factor analysis (CFA), and structural equation modeling (SEM). The findings of SEM were used to test the designed hypotheses that help to generalize the ground reality of CSR and entrepreneurship development in the context of Dailekh district. The three major parts of the analysis can be discussed below.

Principal Component Analysis (PCA)

For factor loading, PCA Varimax was used to identify and extract high-performing items for the constructs. On the other hand, an option with a fixed number (5) of variables and an absolute value above 0.50 was used to make it easier to identify the items with study variables.

Table 2
Factor Loading Items Related to Study Variables

Variables	Code	Items	Loading Score
Independent Variables			
Economic Responsibility (Eco)	Eco1	I think that a business must strive to be profitable to sustain its operations, pay its employees, and provide a return on investment to its owners.	.881
	Eco2	I believe that in order to prevent fraud, insider trading, and accounting deception, a company must adhere to ethical and legal financial practices.	.843
	Eco3	I assure you that a business must pay the prescribed government taxes and other charges on time.	.793
	Eco4	I believe that a company must deliver precise and timely information regarding its financial performance, operations, and societal impact.	.610
	Eco5	I think that a business must invest in research and development to create new goods and services to improve its competitiveness and contribute to the broader economy.	-
Legal Responsibility (Leg)	Leg1	I believe that a business must obey or follow the laws and regulations related with its operations.	.859
	Leg2	I think that a business must protect the personal information of its employees.	.858
	Leg3	I know that a business must fulfill its contractual obligations.	.853
	Leg4	I assure you that a business must follow good corporate governance practices that support to build a strong management system.	.831
	Leg5	I agree that businesses have a legal responsibility to avoid bribery and corruption.	.820
	Leg6	I believe that businesses should resolve disputes with their stakeholders in a fair and equitable manner.	-
Ethical Responsibility (Eth)	Eth1	I think that business must act with honesty and integrity in all of their dealings including customers.	.807
	Eth2	I believe that business should treat all stakeholders fairly	.788
	Eth3	I agree that business must have an ethical responsibility to be transparent in their actions.	.631
	Eth4	I believe that business should act in the best interests of society.	-
	Eth5	I think that business should have ethical leaders who set a positive example for employees and stakeholders.	-
	Eth6	I believe that businesses should protect whistleblowers that report unethical or illegal behavior.	-
Philanthropic Responsibility (Phil)	Phi1	I think that business should contribute to the well-being of society, including through volunteering, charitable giving, and community involvement.	.834

	Phi2	I agree that businesses should prioritize philanthropic initiatives that address social and environmental issues, such as promoting sustainability and supporting education and literacy.	.817
	Phi3	I believe that business should be involved in disaster relief and emergency response efforts, such as providing financial assistance or donating goods and services.	.771
	Phi4	I think that business must support to promote cultural and artistic initiatives that enrich communities, such as sponsoring museums, theaters, or arts programs.	.754
	Phi5	I believe that business should operate public-private partnership programs to create greater social impact and achieve shared philanthropic goals.	.613
Dependent Variables			
Entrepreneurship Development (EntD)	Edv1	I think that access to finance is a critical factor in promoting entrepreneurial initiatives for sustainable business growth.	.816
	Edv2	I believe that supportive policies and regulations, such as tax incentives and streamlined business registration processes, are important for entrepreneurship development.	.791
	Edv3	I agree that ethical aspects of business like honesty, integrity, and transparency support to entrepreneurship development.	.788
	Edv4	I assure that philanthropic initiatives of business such as volunteering works, charity, and social involvement help to entrepreneurial growth.	.765
	Edv5	I believe that collaboration between government, academia, and the private sector is critical for entrepreneurship development.	.765

Source: Survey 2022

Table 2 shows the total number of the items or statements of the dependent and independent variables of the study that are used in factor analysis. Only 22 items were extracted from a total of 27 items through PCA. Due to weak commonalities and cross-loading issues, the remaining items (Eco5, Leg6, Eth4, Eth5, and Eth6) were dropped from the rotated component matrix. Similarly, KMO and Cronbach's alpha calculations were made to determine whether the extracted elements of each construct had adequate sample sizes and reliable data. After conducting PCA, the following findings were made:

Table 3

Variable ways KMO, Eigenvalue, Percentage of Variance, and Cronbach's Alpha

Variables	KMO	Eigenvalue	% of Variance	Cronbach's Alpha
Economic Responsibility (Eco)	.823	3.148	62.954	.831
Legal Responsibility (Leg)	.803	3.337	56.245	.842
Ethical Responsibility (Eth)	.876	4.537	75.623	.935
Philanthropic Responsibility (Phil)	.889	3.703	74.055	.911
Entrepreneurship Development (EntD)	.867	4.288	85.765	.957

Notes: All the extracted constructs and items have appropriate KMO (>.60); Eigenvalue (>1), % of variance (close to 1); Cronbach's Alpha (>.70). This means that, the data set can be used for further analysis like confirmatory factor analysis.

Confirmatory factor analysis (CFA)

In this study, the researcher computed different model fit indices and evaluated the reliability and validity of the data for structural equation modeling. As part of confirmatory factor analysis, factor loading was assessed for each item; only 15 items from the 22 items extracted in PCA were validated for further analysis. For each latent variable, only three items remained. Similarly, the model fit measures were used to assess the overall model fit (P-value, CMIN/DF, RMR, GFI, CFI, and RMSEA), and all values were within their respective common acceptance levels (Hair et al., 2010; Hu & Bentler, 1998; Bentler, 1990; Bagozzi & Yi, 1988). Table 4 and table 5 shows the overall model fit indices and reliability and validity drawn from the CFA.

Table 4

Computation and Analysis of Model Fit Indices for CFA

Model Fit Indices	Recommended Value	Sources	Obtained Value
P-value	≤ 0.05	Bagozzi and Yi (1988)	.000
CMIN/DF	3-5	Hair et al. (2010)	3.177
RMR	≤ 0.05	" "	.017
GFI	>.90	" "	.935
CFI	>.90	Bentler (1990)	0.967
RMSEA	<.08	Hu and Bentler (1998)	0.068

Notes: P-value=Likelihood Ratio, CMIN/DF=Relative X2, RMR=Root Mean Squared Residual, GFI= Goodness of Fit Index, CFI= Comparative Fit Index, RMSEA= Root Mean Square Error of Approximation.

Table 5*Test of Reliability and Validity Measures for Structure Equation Modeling*

	CR	AVE	MSV	MaxR(H)	Leg	EntD	Phil	Eco	Eth
Leg	0.925	0.804	0.325	0.933	0.896				
EntD	0.939	0.837	0.512	0.944	0.570***	0.915			
Phil	0.882	0.713	0.512	0.895	0.529***	0.715***	0.845		
Eco	0.815	0.614	0.182	0.907	0.331***	0.426***	0.376***	0.783	
Eth	0.850	0.658	0.333	0.887	0.485***	0.577***	0.486***	0.410***	0.811

Notes: There are no problems with validity here. Table 5 shows that all the constructs in this study have good internal consistency (high CR), convergent validity (high AVE), and discriminant validity (low MSV and MaxR(H)). This means that the indicators for each construct are reliable, effectively represent the underlying constructs, and are distinct from one another in the model. These findings provide confidence in the measurement quality and construct validity of the study.

Structural equation modeling (SEM)

Several researchers (Sit et al., 2009; Lin & Lee, 2005; 2004; Hair et al., 1998) have recommended a two-step modeling process for performing structural equation modeling (SEM), which involves testing confirmatory factor analysis (CFA) before testing the structure of the model. SEM has three primary benefits. First, it provides a direct approach to managing relationships and can offer statistical efficiency, which is not possible with multiple regression analysis. Second, SEM allows for comprehensive examination of relationships between observed and latent variables (Schaupp et al., 2010; Hoyle, 1995). For this reason, the present study employed PCA for exploratory analysis and used CFA; verifying model fit indices and performing reliability and validity tests before drawing the SEM model for path or hypothesis analysis using IBM SPSS Amos 22 (Saeed et al., 2022). The path diagram of SEM can be illustrated as follows:

Figure 1

Path Diagram for Structural Equation Modeling

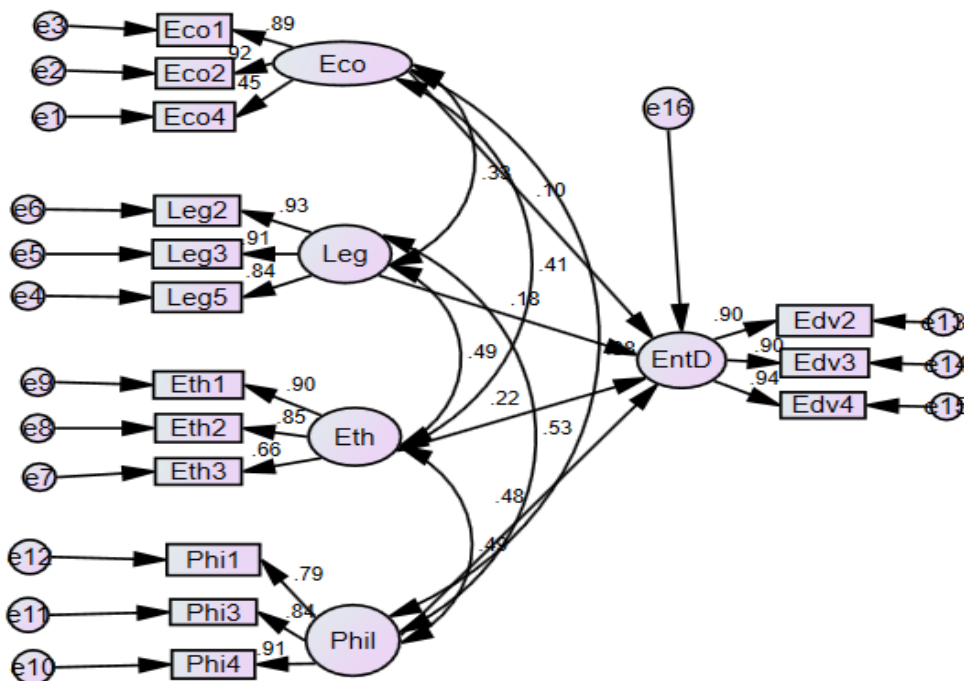

Notes: The SEM diagram is a powerful tool in inferential statistics that facilitates the understanding of the complex relationships between dependent and independent variables in a system. The arrows in the diagram indicate the direction of the effect of one variable on another, and the strength of the effect is represented by a path coefficient.

Table 6

Analysis of Four Designed Alternative Hypotheses through SEM Results

Hypothesis	Path	Estimate	Std. Error	Critical Ratio	P-value	Interpretation
H1	Eco--->EntD	.145	.060	2.427	.015	Significant
H2	Leg--->EntD	.222	.054	4.124	***	Significant
H3	Eth--->EntD	.340	.072	4.715	***	Significant
H4	Phil--->EntD	.543	.054	10.055	***	Significant

Notes: N = 465; **p < 0.01; *p < 0.05; ***p < 0.10; Eco = Economic responsibility; Leg = Legal responsibility; Eth = Ethical responsibility; Phil = Philanthropic responsibility; Entrepreneurship development

Table 6 shows the overall outcomes of SEM for the designed hypotheses. In this study, four different alternative hypotheses were designed to examine the impact of corporate social responsibility (CSR) on entrepreneurship development. Based on the results of path analysis (SEM), the study found that the p-value of economic responsibility is less than 0.05 ($P_{0.015} < 0.05$) level of significance, and the alternative hypothesis (H1) is accepted between a 5 percent and 10 percent level of significance. Thus, economic responsibility significantly impacts entrepreneurship development ($\beta=0.0145$, $t = 2.427$, $p = 0.015$). Similarly, the study also found that the p-value of legal responsibility is less than 0.01 ($P_{0.00} < 0.01$) level of significance, and the alternative hypothesis (H2) is accepted under a 1percent level of significance. Thus, legal responsibility has a significant positive impact on entrepreneurship development ($\beta=0.222$, $t=4.124$, $P=0.000$). On the other hand, the study found that the p-value of the ethical responsibility is less than 0.01 ($P_{0.00} < 0.01$) level of significance, and the alternative hypothesis (H3) is accepted under a 1 percent level of significance. Thus, ethical responsibility has a significant positive impact on entrepreneurial development ($\beta=0.340$, $t = 4.715$, $P = 0.000$). Finally, the study found that the p-value of philanthropic responsibility is less than the 0.01 ($P_{0.00} < 0.01$) level of significance, and the alternative hypothesis (H4) is accepted under the 1percent level of significance. Thus, philanthropic responsibility significantly impacts entrepreneurship development ($\beta=0.543$, $t = 10.055$, $P = 0.000$).

Discussion

The findings of the SEM in this study demonstrate a strongly positive effect of CSR on entrepreneurship development, with all four alternative hypotheses being accepted. This is consistent with previous research that has shown the positive impact of CSR on businesses in terms of reputation, client trust and loyalty, profitability, and sustainability (Vallaster et al., 2019; Awan et al., 2019; Cheng et al., 2018; Ateljevic

& Trivic, 2016; Amaeshi et al., 2016; Carroll, 2015; Rahim, 2013). For example, Vallaster et al. (2019) found that CSR positively impacts the financial performance of SMEs, while Awan et al. (2019) suggest that CSR can enhance a firm's social and environmental reputation. Moreover, Cheng et al. (2018) found that all the social responsibilities conducted by the entrepreneurs supported to promote and develop their entrepreneurial initiatives effectively.

In the context of positivist philosophy and deductive reasoning, the findings of this study demonstrated that all the taken independent variables have significant positive impact on entrepreneurship development. However, the present researcher determined alternative hypotheses to justify fundamental beliefs of Carroll CSR theory within the entrepreneurship development. It means that Carroll CSR theory ensure sustainable development of the entrepreneurship. However, it is important to note that the CSR initiatives undertaken by firms must be relevant to entrepreneurship development. This supports the notion that CSR is not a one-size-fits-all solution, and firms need to tailor their CSR efforts to their specific business and industry (Ateljevic & Trivic, 2016; Amaeshi et al., 2016; Carroll, 2015; Rahim, 2013). Overall, these findings suggest that CSR can be a valuable tool for businesses seeking to enhance their entrepreneurial growth and development.

While the quantitative research strategy has advantages, such as the ability to generalize findings to a larger population, it also has limitations. First, the deductive approach relies heavily on pre-existing theories, which may only sometimes be relevant or accurate for the specific research question being examined. Additionally, the study's use of convenience sampling may introduce selection bias and limit the generalizability of the findings. The reliance on self-reported data from a survey questionnaire may also introduce response bias, where participants may not accurately represent their true beliefs or behaviors. Finally, while the study conducted various

validity and reliability tests, these measures may not fully capture the complexity of the examined constructs, and there may be other factors that should have been accounted for in the study's methodology. Therefore, the findings should be interpreted cautiously and not assumed to apply universally.

Conclusion and Recommendations

Despite the importance of evaluating the relationship between corporate social responsibility and entrepreneurial development, prior research still needs to examine the significance of CSR in this particular setting. Since the current understanding of the mechanisms that drive entrepreneurial success still needs to be improved, it is necessary to conduct further research. Therefore, the present study aims to investigate the impact of CSR on entrepreneurship development, particularly in the context of SMEs. As per the study results, all four alternative hypotheses were accepted, which means the four components of CSR (economic, legal, ethical, and philanthropic responsibility) have an enormously positive effect on entrepreneurship development. However, the CSR initiatives firms participate in are more obviously pertinent to expanding entrepreneurship. Through sustaining CSR, businesses can contribute to the expansion of entrepreneurship and aid in the long-term sustainability of growth. The interested parties should therefore consider incorporating CSR into their companies.

The present study used SEM to demonstrate the positive impact of CSR on entrepreneurship development. The study identified that all the independent variables play a vital role in the development of SMEs. Economic responsibility is crucial, as entrepreneurs must strive for profitability to sustain their operations and remunerate critical stakeholders. To prevent fraudulent activities, ethical and legal financial practices must be adhered to, and accurate and timely information about financial performance and operations should be delivered that leads to the development of

businesses. Legal responsibility is also essential as entrepreneurs must protect the personal information of employees and others, fulfill contractual obligations to concerned parties, and avoid bribery, corruption, and business malfunctions that lead to entrepreneurship development. Moreover, the study emphasizes the importance of ethical and philanthropic responsibilities in business firms for entrepreneurship development. It suggests that businesses should act honestly, treat all stakeholders fairly, and be transparent. Additionally, companies should contribute to society through volunteering, charity, donations, and community involvement. They should also provide financial and non-financial assistance in disaster relief and emergencies and support cultural and artistic initiatives through sponsorships and social campaigns.

In conclusion, this study's findings show that CSR initiatives can foster entrepreneurship and should be considered by businesses and policymakers to promote social welfare and economic growth. Therefore, business owners should concentrate on CSR initiatives to ensure the long-term viability of their companies. On the other hand, there is a need for more exemplary academic and research-based work on the expansion of entrepreneurial development in Dailekh, the Karnali Province, and throughout Nepal. Aside from that, because CSR and entrepreneurial development are universal phenomenon today, insightful suggestions and recommendations for future researchers have been made based on literature reviews, methodological paradigms, and findings.

References

- Ahmed, A., & Nwankwo, S. (2013). Entrepreneurship development in Africa: an overview. *World Journal of Entrepreneurship, Management and Sustainable Development*, 9(2/3), 82-86. <https://doi.org/10.1108/20425961201300006>
- Ali, H. Y., Danish, R. Q., & Asrar-ul-Haq, M. (2020). How corporate social responsibility boosts firm financial performance: The mediating role of

- corporate image and customer satisfaction. *Corporate Social Responsibility and Environmental Management*, 27(1), 166-177.
<https://doi.org/10.1002/csr.1747>
- Amaeshi, K., Adegbite, E., Ogbechie, C., Idemudia, U., Kan, K. A. S., Issa, M., & Anakwue, O. I. (2016). Corporate social responsibility in SMEs: A shift from philanthropy to institutional works? *Journal of business Ethics*, 138, 385-400.
<https://doi.org/10.1007/s10551-015-2611-7>
- Amaeshi, K., Nnodim, P., & Onyeka, O. (2013). *Corporate social responsibility, entrepreneurship, and innovation*. Routledge.
<https://doi.org/10.4324/9780203081945>
- Amran, A., Lee, S. P., & Devi, S. S. (2014). The influence of governance structure and strategic corporate social responsibility toward sustainability reporting quality. *Business Strategy and the environment*, 23(4), 217-235.
<https://doi.org/10.1002/bse.1786>
- Anderson, T. L., Leal, D. R., Anderson, T. L., & Leal, D. R. (2001). Marketing Garbage: The Solution to Pollution. *Free Market Environmentalism*, 123-142.
https://doi.org/10.1007/978-1-349-62852-2_7
- Ardichvili, A., Mitchell, J. A., & Jondle, D. (2009). Characteristics of ethical business cultures. *Journal of business ethics*, 85, 445-451.
<https://doi.org/10.1007/s10551-008-9782-2>
- Ateljevic, J., & Trivic, J. (2016). *Economic development and entrepreneurship in transition economies*. Springer. <https://doi.org/10.1007/978-3-319-30662-5>

- Azmat, F., & Samaratunge, R. (2009). Responsible entrepreneurship in developing countries: Understanding the realities and complexities. *Journal of Business Ethics*, 90, 437-452. <https://doi.org/10.1007/s10551-009-0063-y>
- Baden, D. (2014). Look on the bright side: A comparison of positive and negative role models in business ethics education. *Academy of Management Learning & Education*, 13(2), 154-170. <https://doi.org/10.5465/amle.2012.0359>
- Bagozzi, R. P., & Yi, Y. (1988). On the evaluation of structural equation models. *Journal of the academy of marketing science*, 16, 74-94. <https://doi.org/10.1007/BF02723327>
- Batchenko, L., & Dielini, M. (2017). International aspects of state regulation of socio-economic responsibility of entrepreneurship: experience for Ukraine. *Baltic Journal of Economic Studies*, 3(5), 13-18. <https://doi.org/10.30525/2256-0742/2017-3-5-13-18>
- Beauchamp, T. L., Bowie, N. E., & Arnold, D. G. (Eds.). (2004). *Ethical theory and business*. New York: Pearson Education.
- Belas, J., Čera, G., Dvorský, J., & Čepel, M. (2021). Corporate social responsibility and sustainability issues of small-and medium-sized enterprises. *Corporate Social Responsibility and Environmental Management*, 28(2), 721-730. <https://doi.org/10.1002/csr.2083>
- Bentler, P. M. (1990). Comparative fit indexes in structural models. *Psychological bulletin*, 107(2), 238. <https://doi.org/10.1037/0033-2909.107.2.238>
- Bird, F. (2009). The ethical responsibilities of businesses in developing areas. *Journal of Business Ethics*, 89, 85-97. <https://doi.org/10.1007/s10551-008-9996-8>

- Bocquet, R., Le Bas, C., Mothe, C., & Poussing, N. (2019). Strategic CSR for innovation in SMEs: Does diversity matter? *Long Range Planning*, 52(6), 101913. <https://doi.org/10.1016/j.lrp.2018.08.003>
- Branco, M. C., & Rodrigues, L. L. (2008). Factors influencing social responsibility disclosure by Portuguese companies. *Journal of business Ethics*, 83, 685-701. <https://doi.org/10.1007/s10551-007-9633-1>
- Bryman, A. (2006). Integrating quantitative and qualitative research: how is it done? *Qualitative research*, 6(1), 97-113. <https://doi:10.1016/j.leaqua.2004.09.007>
- Carroll, A. B. (1991). The pyramid of corporate social responsibility: Toward the moral management of organizational stakeholders. *Business horizons*, 34(4), 39-48. [https://doi.org/10.1016/0007-6813\(91\)90005-G](https://doi.org/10.1016/0007-6813(91)90005-G)
- Carroll, A. B. (1999). Corporate social responsibility: Evolution of a definitional construct. *Business & society*, 38(3), 268-295. <https://doi.org/10.1177/000765039903800303>
- Carroll, A. B. (2000). Ethical challenges for business in the new millennium: Corporate social responsibility and models of management morality. *Business Ethics Quarterly*, 10(1), 33-42. <https://doi.org/10.2307/3857812>
- Carroll, A. B. (2015). Corporate social responsibility. *Organizational dynamics*, 44(2), 87-96. <https://doi.org/10.1016/j.orgdyn.2015.03.005>
- Carroll, A. B. (2016). Carroll's pyramid of CSR: taking another look. *International journal of corporate social responsibility*, 1(1), 1-8. <https://doi.org/10.1186/s40991-016-0002-6>

- Chell, E., Spence, L. J., Perrini, F., & Harris, J. D. (2016). Social entrepreneurship and business ethics: Does social equal ethical? *Journal of business ethics*, 133, 619-625. <https://doi.org/10.1007/s10551-014-2343-4>
- Claydon, J. (2011). A new direction for CSR: the shortcomings of previous CSR models and the rationale for a new model. *Social Responsibility Journal*, 7(3), 405-420. <https://doi.org/10.1108/17471111111146609>
- Cropper, M. L., & Oates, W. E. (1992). Environmental economics: a survey. *Journal of economic literature*, 30(2), 675-740. <https://doi.org/10.2307/2728254>
- Das, M., Rangarajan, K., & Dutta, G. (2020). Corporate sustainability in SMEs: An Asian perspective. *Journal of Asia Business Studies*. <https://doi.org/10.1108/JABS-08-2019-0316>
- Dathe, T., Dathe, R., Dathe, I., & Helmold, M. (2022). Corporate Social Responsibility (CSR) Versus Environmental Social Governance (ESG). In *Corporate Social Responsibility (CSR), Sustainability and Environmental Social Governance (ESG) Approaches to Ethical Management* (pp. 117-141). https://doi.org/10.1007/978-3-030-92357-0_9
- Dioneo-Adetayo, E. A. (2006). Factors influencing attitude of youth towards entrepreneurship. *International Journal of Adolescence and Youth*, 13(1-2), 127-145. <https://doi.org/10.1080/02673843.2006.9747829>
- Evans, J. S. B., & Over, D. E. (1997). Rationality in reasoning: The problem of deductive competence. *Cahiers de Psychologie Cognitive/Current Psychology of Cognition*.
- Fassin, Y., & Buelens, M. (2011). The hypocrisy-sincerity continuum in corporate communication and decision making: A model of corporate social

- responsibility and business ethics practices. *Management Decision*, 49(4), 586-600. <https://doi.org/10.1108/00251741111128021>
- Gherghina, Ș. C., Botezatu, M. A., Hosszu, A., & Simionescu, L. N. (2020). Small and medium-sized enterprises (SMEs): The engine of economic growth through investments and innovation. *Sustainability*, 12(1), 347. <https://doi.org/10.3390/su12010347>
- Gielnik, M. M., Zacher, H., & Frese, M. (2012). Focus on opportunities as a mediator of the relationship between business owners' age and venture growth. *Journal of Business Venturing*, 27(1), 127-142. <https://doi.org/10.1016/j.jbusvent.2010.09.002>
- Grbac, B., & Lončarić, D. (2009). Ethics, social responsibility and business performance in a transition economy. *EuroMed Journal of Business*, 4(2), 143-158. <https://doi.org/10.1108/14502190910952806>
- Greening, D. W., & Turban, D. B. (2000). Corporate social performance as a competitive advantage in attracting a quality workforce. *Business & society*, 39(3), 254-280. <https://doi.org/10.1177/000765030003900302>
- Hair, J. F., Black, W. C., Babin, B. J., & Anderson, R. E. (2010). *Multivariate data analysis* (7th ed.). Prentice Hall. [https://doi.org/10.1016/0304-405X\(90\)90067-Q](https://doi.org/10.1016/0304-405X(90)90067-Q)
- Hair, J., Andreson, R., Tatham, R., & Black, W. (1998). *Multivariate data analysis*. 5th (ed) Prentice-Hall Inc. *Unites States of America*.
- Haldar, S. (2021). Sustainable entrepreneurship development in the renewable energy sector: Insights from Gujarat, India. *African Journal of Science, Technology,*

Innovation and Development, 13(7), 873-885.
<https://doi.org/10.1080/20421338.2020.1796004>

Halme, M., & Laurila, J. (2009). Philanthropy, integration or innovation? Exploring the financial and societal outcomes of different types of corporate responsibility. *Journal of business ethics*, 84, 325-339.
<https://doi.org/10.1007/s10551-008-9703-0>

Harrison, D. E., Ferrell, O. C., Ferrell, L., & Hair, Jr, J. F. (2020). Corporate social responsibility and business ethics: conceptualization, scale development and validation. *Journal of Product & Brand Management*, 29(4), 431-439.
<https://doi.org/10.1108/JPBM-09-2019-2354>

Hassan, A. (2016). Islamic ethical responsibilities for business and sustainable development. *Humanomics*, 32(1), 80-94. <https://doi.org/10.1108/H-03-2015-0031>

Hoyle, R. H. (1995). The role of personality in scientific and technical excellence. *Clinical Psychology Review*, 15(8), 681–706. [https://doi.org/10.1016/0272-7358\(95\)00026-4](https://doi.org/10.1016/0272-7358(95)00026-4)

Hu, L. T., & Bentler, P. M. (1998). Fit indices in covariance structure modeling: Sensitivity to underparameterized model misspecification. *Psychological methods*, 3(4), 424-53. <https://doi.org/10.1037/1082-989X.3.4.424>

Ibrahim, S., Jamali, D., & Karatas-Ozkan, M. (2012). Corporate social responsibility (CSR) in Small and Medium-Sized Enterprises: A developing country perspective. In *Social and sustainable enterprise: Changing the nature of business* (Vol. 2, pp. 167-192). <https://doi.org/10.1108/S2040-724620140000002011>

- Iwannanda, R., & Adiputra, I. W. J. (2017). Philanthropic corporate social responsibility: A case study. *International Journal of Academic Research in Business and Social Sciences*, 7(6), 876-886. <https://doi.org/10.6007/IJARBSS/v7-i6/3193>
- Jindal, M. K., & Bhardwaj, A. (2016). Entrepreneurship development in India: A new paradigm. In *Proceedings of the world congress on engineering* (Vol. 2, pp. 724-726). https://www.iaeng.org/publication/WCE2016/WCE2016_pp724-726.pdf
- Joshi, P. (2019). Integration of CSR and branding: A strategy to accomplish a competitive edge. *International Journal of Management Research and Reviews*, 9(3), 10-16. <https://doi.org/10.18488/journal.63.2019.93.10.16>
- Lee, K. H., Herold, D. M., & Yu, A. L. (2016). Small and medium enterprises and corporate social responsibility practice: A Swedish perspective. *Corporate Social Responsibility and Environmental Management*, 23(2), 88-99. <https://doi.org/10.1002/csr.1354>
- Leonidou, E., Christofi, M., Vrontis, D., & Thrassou, A. (2020). An integrative framework of stakeholder engagement for innovation management and entrepreneurship development. *Journal of Business Research*, 119, 245-258. <https://doi.org/10.1016/j.jbusres.2020.05.047>
- Lin, H. F., & Lee, G. G. (2004). Impact of organizational learning and knowledge management factors on e-business adoption. *Management Decision*, 42(1), 99-113. <https://doi.org/10.1108/00251740410517526>
- Lin, H. F., & Lee, G. G. (2005). The influence of organizational learning on organizational commitment in e-business adoption. *Journal of Organizational*

Change Management, 18(2), 143–155.
<https://doi.org/10.1108/09534810510593043>

- Liu, W., Wei, Q., Huang, S. Q., & Tsai, S. B. (2017). Doing good again? A multilevel institutional perspective on corporate environmental responsibility and philanthropic strategy. *International journal of environmental research and public health*, 14(10), 1283. <https://doi.org/10.3390/ijerph14101283>
- Lordkipanidze, M., Brezet, H., & Backman, M. (2005). The entrepreneurship factor in sustainable tourism development. *Journal of cleaner production*, 13(8), 787-798. <https://doi.org/10.1016/j.jclepro.2004.04.009>
- Lu, J., Ren, L., Zhang, C., Rong, D., Ahmed, R. R., & Streimikis, J. (2020). Modified Carroll's pyramid of corporate social responsibility to enhance organizational performance of SMEs industry. *Journal of Cleaner Production*, 271, 122456. <https://doi.org/10.1016/j.jclepro.2020.122456>
- Manzoor, F., Wei, L., & Siraj, M. (2021). Small and medium-sized enterprises and economic growth in Pakistan: An ARDL bounds cointegration approach. *Heliyon*, 7(2), e06340. <https://doi.org/10.1016/j.heliyon.2021.e06340>
- Martinez-Conesa, I., Soto-Acosta, P., & Palacios-Manzano, M. (2017). Corporate social responsibility and its effect on innovation and firm performance: Empirical research in SMEs. *Journal of cleaner production*, 142, 2374-2383. <https://doi.org/10.1016/j.jclepro.2016.11.149>
- Mazzei, M. J., Flynn, C. B., & Haynie, J. J. (2016). Moving beyond initial success: Promoting innovation in small businesses through high-performance work practices. *Business Horizons*, 59(1), 51-60. <https://doi.org/10.1016/j.bushor.2015.08.003>

- McWilliams, A., Siegel, D. S., & Wright, P. M. (2006). Corporate social responsibility: Strategic implications. *Journal of management studies*, 43(1), 1-18. <https://doi.org/10.1111/j.1467-6486.2006.00580.x>
- Mehta, K., & Sharma, R. (2016). SMEs and corporate social responsibility: Indian perception. *SCMS Journal of Indian Management*, 13(3), 58-67. <https://doi.org/10.1177/097570601601300305>
- Meyer, M. H., & Crane, F. G. (2010). *Entrepreneurship: An innovator's guide to startups and corporate ventures*. Sage. <https://doi.org/10.4135/9781483380328>
- Miragaia, D. A. M., Martins, C. I. N., Kluka, D. A., & Havens, A. (2015). Corporate social responsibility, social entrepreneurship and sport programs to develop social capital at community level. *International review on public and nonprofit marketing*, 12, 141-154. <https://doi.org/10.1007/s12208-015-0139-2>
- Morris, M. H., Schindehutte, M., Walton, J., & Allen, J. (2002). The ethical context of entrepreneurship: Proposing and testing a developmental framework. *Journal of Business ethics*, 40(4), 331-361. <https://doi.org/10.1023/A:1019681527975>
- Murphy, P. E. (2009). The relevance of responsibility to ethical business decisions. *Journal of business ethics*, 90, 245-252. <https://doi.org/10.1007/s10551-009-0010-5>
- Nguyen, Q. A., & Mort, G. S. (2016). Economic reform and entrepreneurship in Vietnam: A policy perspective. *Economic development and entrepreneurship in transition economies: Issues, obstacles and perspectives*, 109-127. <https://doi.org/10.1108/978-1-78635-442-020161007>

- Perrini, F.; Russo, A. & Tencati, A. (2007). CSR Strategies of SMEs and Large Firms: Evidence from Italy. *Journal of Business Ethics*. 74, 285-300. <https://doi.org/10.1007/s10551-007-9512-y>
- Prahalad, V. N. (2014). Human impacts and saltmarsh loss in the Circular Head coast, north-west Tasmania, 1952–2006: implications for management. *Pacific Conservation Biology*, 20(3), 272-285. <https://doi.org/10.1071/PC140272>
- Rahdari, A., Sepasi, S., & Moradi, M. (2016). Achieving sustainability through Schumpeterian social entrepreneurship: The role of social enterprises. *Journal of cleaner production*, 137, 347-360. <https://doi.org/10.1016/j.jclepro.2016.07.115>
- Rahim, M. M. (2013). Legal regulation of corporate social responsibility. *CSR, Sustainability, Ethics & Governance*. <https://doi.org/10.1007/s13520-013-0024-2>
- Raimi, L., Akhuemonkhan, I., & Ogunjirin, O. D. (2015). Corporate Social Responsibility and Entrepreneurship (CSRE): antidotes to poverty, insecurity and underdevelopment in Nigeria. *Social Responsibility Journal*, 11(1), 56-81. <https://doi.org/10.1108/SRJ-08-2013-0116>
- Ramasastri, A. (2015). Corporate social responsibility versus business and human rights: Bridging the gap between responsibility and accountability. *Journal of Human Rights*, 14(2), 237-259. <https://doi.org/10.1080/14754835.2015.1020091>
- Saeed, S., Singh, S., & Dwivedi, Y. K. (2022). Understanding the adoption of blockchain technology in healthcare: An empirical investigation. *International Journal of Information Management*, 62, 102331. <https://doi.org/10.1016/j.ijinfomgt.2021.102331>

- Schaupp, L. C., Carter, L., & McBride, M. E. (2010). E-commerce product recommendation agents: Use, characteristics, and impact. *Journal of Marketing Theory and Practice*, 18(1), 55–72. <https://doi.org/10.2753/MTP1069-6679180105>
- Schwartz, M. S. (2011). *Corporate social responsibility: An ethical approach*. Broadview Press.
- Sekaran, U., & Bougie, R. (2016). *Research methods for business: A skill building approach*. John Wiley & Sons.
- Sekliuckiene, J., & Kisielius, E. (2015). Development of social entrepreneurship initiatives: a theoretical framework. *Procedia-Social and Behavioral Sciences*, 213, 1015-1019. <https://doi.org/10.1016/j.sbspro.2015.11.534>
- Shinkafi, A. A., & Ali, N. A. (2018). Entrepreneurship Development in Islamic Economics. In *New Developments in Islamic Economics* (pp. 3-18). Emerald Publishing Limited. <https://doi.org/10.1108/978-1-78743-950-820181001>
- Sigdel, B., & Amponstira, F. (2020). Effect of Corporate Social Responsibility on Firms Profitability: A Study on Small and Medium Enterprises in Pokhara City, Nepal. *International Business Research*, 13(10), 1-76. <https://doi.org/10.5539/ibr.v13n10p1>
- Sit, J., Merrilees, B., & Birch, D. (2009). A brand new world: A comparison of brand new and traditional brands in the Hong Kong fashion market. *Journal of Fashion Marketing and Management*, 13(4), 502–520. <https://doi.org/10.1108/13612020910985261>

- Smith, V., & Langford, P. (2009). Evaluating the impact of corporate social responsibility programs on consumers. *Journal of Management & Organization*, 15(1), 97-109. <https://doi.org/10.1017/S1833367200001185>
- Streimikiene, D., & Ahmed, R. R. (2021). Corporate social responsibility and brand management: Evidence from Carroll's pyramid and triple bottom line approaches. *Technological and Economic Development of Economy*, 27(4), 852-875. <https://doi.org/10.3846/tede.2021.14206>
- Tashakkori, A., & Creswell, J. W. (2007). The new era of mixed methods. *Journal of mixed methods research*, 1(1), 3-7. <https://doi.org/10.1177/2345678906293042>
- Tewari, R., & Pathak, T. (2014). Sustainable CSR for micro, small and medium enterprises. *Journal of Management & Public Policy*, 6(1), 34-44. <https://doi.org/10.1177/0973703020918634>
- Tietenberg, T., & Folmer, H. (2000). *The international yearbook of environmental and resource economics 2000/2001*. Edward Elgar Publishing. <https://doi.org/10.4337/9781843763154>
- Vallaster, C., Kraus, S., Lindahl, J. M. M., & Nielsen, A. (2019). Ethics and entrepreneurship: A bibliometric study and literature review. *Journal of Business Research*, 99, 226-237. <https://doi.org/10.1016/j.jbusres.2019.01.017>
- Valliere, D., & Peterson, R. (2009). Entrepreneurship and economic growth: Evidence from emerging and developed countries. *Entrepreneurship & Regional Development*, 21(5-6), 459-480. <https://doi.org/10.1080/08985620902935968>

- Windsor, D. (2001). Corporate Social Responsibility: A Theory of the Firm Perspective: Some Comments. *Academy of Management Review*, 502-504. <https://doi.org/10.5465/amr.2001.4378011>
- Wu, B., Jin, C., Monfort, A., & Hua, D. (2021). Generous charity to preserve green image? Exploring linkage between strategic donations and environmental misconduct. *Journal of business research*, 131, 839-850. <https://doi.org/10.1016/j.jbusres.2021.02.040>
- Wu, Y., Farrukh, M., Raza, A., Meng, F., & Alam, I. (2021). Framing the evolution of the corporate social responsibility and environmental management journal. *Corporate Social Responsibility and Environmental Management*, 28(4), 1397-1411. <https://doi.org/10.1002/csr.2127>
- Yaluner, E. V., Chesnova, O. A., Ivanov, S. A., Mikheeva, D. G., & Kalugina, Y. A. (2019). Entrepreneurship development: technology, structure, innovations. *International Journal of Recent Technology and Engineering*, 8(2), 6020-6025. <https://doi.org/10.35940/ijrte.B1305.0982S219>
- Yu, H. C., Kuo, L., & Kao, M. F. (2017). The relationship between CSR disclosure and competitive advantage. *Sustainability Accounting, Management and Policy Journal*, 8(5), 547-570. <https://doi.org/10.1108/SAMPJ-02-2016-0015>
- Zhang, S. X., & Cueto, J. (2017). The study of bias in entrepreneurship. *Entrepreneurship theory and Practice*, 41(3), 419-454. <https://doi.org/10.1111/etap.12209>