

## SHORT COMMUNICATION

## ESTABLISHMENT AND MANAGEMENT OF COVID-19 TESTING MOLECULAR LABORATORY IN MINIMAL RESOURCE SETTING, CHALLENGES AND ISSUES REPORTED FROM BIRGUNJ, NEPAL – AN EXPERIENCE OF PATHOLOGIST

Pathak Neera,<sup>1+</sup> Upadhyaya Madan K,<sup>1+</sup> Manandhar Varsha <sup>2</sup>

1+ = Equally contributing authors

<sup>1+</sup> Narayani Hospital, Birgunj Metropolitan City, Parsa, Nepal<sup>2</sup> Lecturer, Pokhara Academy for Health Sciences, Kaski, Nepal

**Date of Submission** : May 10, 2021  
**Date of Revision** : Jun 20, 2021  
**Date of Acceptance** : Jun 21, 2021  
**Date of Publication** : July 19, 2021

**\*Correspondence to:**

Dr. Neera Pathak, MD  
 Pathologist, Narayani Hospital, Birgunj Metropolitan City, Parsa, Nepal  
 Email: neerap333@gmail.com, Cell: 9847407749

**Citation:**

Pathak N, Upadhyaya MK, Manandhar V. Establishment & Management of COVID-19 Testing Molecular Laboratory in Minimal Resource Setting, Challenges & Issues Reported from Birgunj, Nepal – An Experience of Pathologist. Medphoenix. 2021;6(1):66-70

**DOI:** <https://doi.org/10.3126/medphoenix.v6i1.37037>

**Conflict of interest:** None, **Funding:** None

**Publisher:** National Medical College Pvt. Ltd. **MedPhoenix - Journal of National Medical College (JNMC); 2021,6(1), available at [www.jnmc.com.np](http://www.jnmc.com.np)**

ISSN:2631-1992 (Online); ISSN:2392-425X (Print)



This work is licensed under a Creative Commons Attribution 4.0 International License.

**ABSTRACT**

Nepal reported the first COVID-19 case on January 23, 2020. A rapid increase in the number of COVID-19 cases was being reported in Nepal as of June 2020. Limited molecular laboratory capacity in a minimal resource setting is a challenge in the diagnosis of the ever-increasing cases. We share the experience and challenges in the rapid establishment of COVID-19 testing laboratory in Birgunj of Parsa district which is one of the SARS-CoV-2 transmission hotspots in Nepal. The initial step in establishing the COVID-19 molecular testing laboratory were i) identifying a suitable space ii) renovating it and iii) mobilizing materials including consumables, mainly from the hospital store and administration. A chain of experimental design was set up with distinct laboratories to standardize the extraction of samples, preparation of the master mix and detection. At the commencement of sample testing, laboratory contamination was among the primary challenges faced. The source of the contamination was identified in the master mix room and resolved. The established COVID-19 testing lab (Narayani PCR Lab) has tested more than 40,000 samples as of 31st August, 2020 and is now one of the preferred laboratory for CoVID-19 testing. The lessons learnt may benefit the further establishment of testing laboratories for COVID-19 and/or other epidemic/pandemic diseases in resource-limited settings.

**Keywords:** Biosafety; Contamination; CoVID-19; Molecular laboratory; Polymerase chain reaction (PCR)

**INTRODUCTION**

The first case of Severe Acute Respiratory Syndrome caused by Corona Virus-Type 2(SARS-CoV2) in Nepal was reported on January 23, 2020 in a student returning from Wuhan, China.<sup>1</sup> The transmission of SARS-CoV-2 within Nepal started from the end of March causing 17344 infections and 39 (0.2%) deaths by July 16, 2020 with all seven provinces and 77 districts reporting confirmed Corona Virus Infectious Diseases (COVID-19) cases.<sup>2</sup> Nepal had limited capacity in the molecular diagnosis of corona viruses when there was a significant rise in COVID-19 cases. The lead national referral laboratory, the National Public Health Laboratory (NPHL) started a COVID-19 testing with real time PCR on 26<sup>th</sup> January 2020.<sup>3</sup> However, the limited testing capacity at NPHL could not keep pace with the increasing demand for testing. Considering the need to expand COVID 19 testing nationwide, the team took the initiatives to establish

complementary COVID-19 testing laboratories within the Bagmati province followed by other provinces of Nepal. Later on, several veterinary laboratories, medical colleges, research institutes and hospitals in the country joined the effort by establishing their own COVID-19 testing laboratories following the interim guidelines of NPHL.

Birgunj, which lies in Parsa district, is the largest city in province 2 of Nepal and shares its border with Raxaul of India.<sup>4,5</sup> A vibrant and busy industrial and commercial city, this metropolitan has rightly been called the “Gateway to Nepal” and has been the commercial capital of the country due to its strategic location on the principal transit point for trade between Nepal and India.<sup>4</sup> Poor health hygiene, lack of social distancing measures, immigration of people from India without surveillance for COVID-19,

and populous cities in this region are the major factors behind Birgunj and Parsa becoming hotspots of disease transmission in Nepal.<sup>4,5</sup>

### APPROACH

The Narayani hospital located in Birgunj is a historic government institute, but with scarce human resources and infrastructure with respect to its population. The hospital laboratory was as good as inactive due to weak procurement systems for chemical reagents and maintenance of equipment. Additionally, the key equipment for molecular laboratory such as micro-centrifuges, refrigerators, biosafety cabinets, vortex, hotplate and micropipettes were not available.

At the face of rapid surge of COVID-19 cases, establishment of a COVID-19 molecular laboratory was planned. As a coordinated effort to combat the disease, a multi-disciplinary steering committee was formed by hospital administration to lead the laboratory establishment. The central team comprised of the Medical superintendent, head of the department of Pathology, chief medical technologist, quality officer, safety officer and the hospital store team leader. The team started identifying space for the laboratory along with mobilizing materials and consumables.

### SELECTION AND RENOVATION OF STANDARD ROOMS

COVID-19 molecular laboratory testing has its own set of safety requirements<sup>3</sup>. Due to the limitations in the existing laboratory space for bio-safety level-2 in the hospital, we started a search for a separate space to meet the safety standards and spacious enough for sample storage, processing and disinfection. Consequently, a space containing four separate big rooms inside one open access door; previously used for family planning program at the first floor of the indoor section of the hospital was found suitable. The room was partitioned with aluminium metal frames and windows with adjoining entrance doors into six dedicated rooms for sample reception, aliquot preparation, RNA extraction, master mixing, detection and amplification, and data management. To ensure safety and security, the main entrance corridor was outfitted with an iron gate outside and 2 wooden doors inside. One room was allocated for washroom inside the same space which included hot and cold water facilities. Six rooms were fully setup and painted within two weeks. Eye wash and hand wash basins were placed both inside and outside the laboratory premises. World Health Organization (WHO) documents and experiences from the virology units at the NPHL and provincial laboratories were consulted to design the room's structure and workflow. (Fig 1)

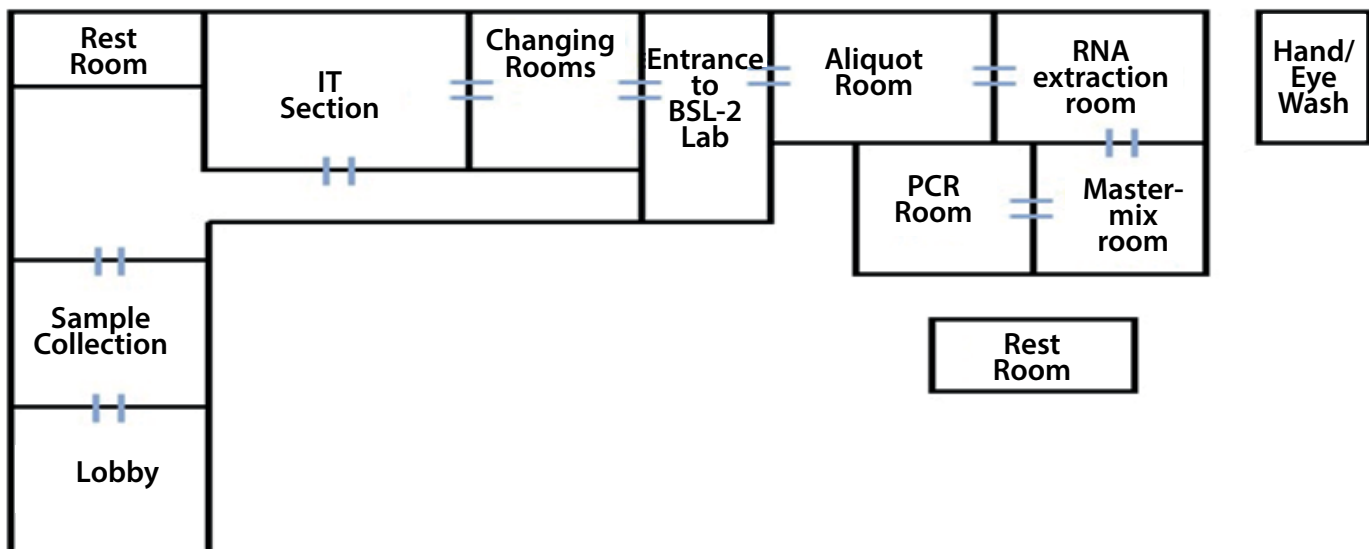

Fig 1: Floor plan of COVID laboratory

### ORGANIZING THE LAB

A separate setup for dirty (sample reception and extraction) and clean rooms (master mix) was done. Sample flow was organized in such a way that the dirty rooms did not contaminate the clean rooms (unidirectional workflow).

Experts from the molecular lab teams at NPHL helped with calibrating the RT-PCR machine. The central Information

Technology (IT) team installed the software. However, on the second day of the machine calibration, a power fluctuation damaged the desktop. So, Uninterruptible Power Supply system was installed by the electrical repair unit after several requests.

During the first trial test, the biosafety cabinet filter was malfunctioning. Biomedical engineer helped to solve the

issues at hand by communicating with their colleagues and the representatives of Nepal Bio-medical Engineer's association. After an intensive period of problem identification by the team, it was concluded that the cabinet needed replacement. It took almost 2 weeks to buy and install another biosafety cabinet. However, the glass window of the cabinet was broken during transportation. The maintenance team helped change the glass window the next day. In parallel, part of the team was mobilizing instruments such as pipettes, tips, vortex, centrifuges, hot water bath, ice-maker, distilled water to start the actual testing. Most of them were bought from the local suppliers.



**Fig 2: (a) Entrance (b) Sealed windows (c) Installed PCR machine (d) Handwash areas**



**Fig 3: (a) Broken glass of biosafety cabinet, (b) Malfunctioning filter, (c) New biosafety cabinet.**

## CONSUMABLES AND REAGENTS

PCR reagents and Personal Protection Equipment (PPE) were made available by the hospital administration, through the aid from the Logistic Management Division, Teku as well as social organizations. (Fig 4)

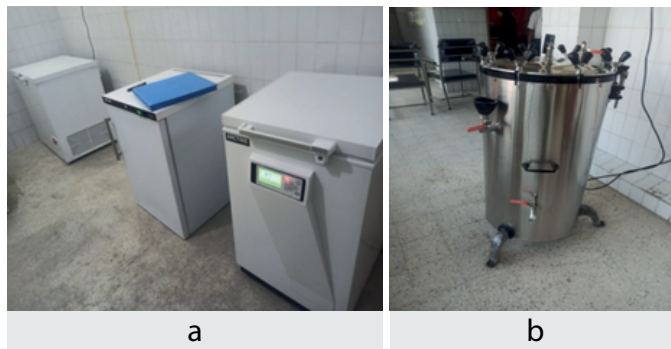

**Fig 4: Consumables supplied by hospital administration (a) Refrigerators, (b) Autoclave machine**

## INITIATION

The new laboratory was named Narayani Covid-19 PCR Laboratory. The team had received training and support from virology experts of NPHL. The first 23 samples for testing were collected from mass screening.

## SAMPLE COLLECTION AND TESTING

Regular COVID-19 response of Narayani hospital involved investigation of suspected and confirmed cases, contact tracing and follow-up of the cases and their contacts. People staying in quarantine centers for 2 weeks or having a history of travel to COVID-19 affected countries or communities inside Nepal irrespective of the presence or absence of symptoms were identified along with documentation as per the protocol developed by the national reference laboratory. Oropharyngeal and/or nasopharyngeal samples were collected, stored and transported using standard Viral Transport Medium (VTM) reinforced by triple packaging, for SARS-CoV-2 testing in the laboratory.

**Fig 4: Consumables supplied by hospital administration (a) Refrigerators, (b) Autoclave machine**

The first PCR testing was done on Baisakh 20, 2077 (2<sup>nd</sup> May, 2020). At the end of the day, during result interpretation, we noticed no proper graph of internal control. The team had a quick communication with nearby laboratories. Fortunately, one of the experts from Provincial laboratory, Hetauda told us that they had the required buffer reagents left over from recent calibration and hence we sent the vehicle with cold chain box to bring it and the internal control reagent was prepared. The machine was retested with known positive sample.

### ONE STEP FURTHER

Meanwhile Birgunj municipality was conducting mass screening (one sample per house). The workload was enormous and we had to run 600 samples per day. This led to a huge burden to the team. A request was made with the executive members of the municipality office for human resource management as well as infrastructural development. After a couple of months, a new RT PCR machine bought by municipality arrived for the team's use. The instrument was ready to use with required calibration and the required software was installed safely. The municipality also helped us by providing reagents as well as biosafety cabinet, computer, photocopy machine and printer.

### MAJOR CHALLENGES FACED

The ambivalence in the results was a major issue in the beginning. There were no apparent flaws in the system; however the flaw in the results could not be interpreted. Similar tests and results had to be repeated multiple times. There was a suspicion that the samples might have been contaminated with other samples. In order to address this issue, the core team started investigating for the potential suspects for the contamination.

The team ran the experiment again. However, the result was further frustrating as it showed that the contamination had not yet been removed. Our team concluded that this could be the result of the contamination of the entire laboratory for which the lab was closed for 24 hours to turn down faults and flaws. Following this, the team had to face extreme pressure from the public and the local government for the inability to cater test results in the given limited timeframe.

### TROUBLESHOOTING: A. EXTRACTION ROOM

The entire extraction room, the safety cabinet and all materials including refrigerators were cleaned using hypochlorite solution and 70% alcohol to control contamination that may interfere with assay detection. The room was fumigated with aerial fumigator and neutralized. The safety cabinet was exposed to UV light for a couple of days.

### TROUBLESHOOTING: B. AMPLIFICATION AND DETECTION ROOMS

In the amplification room, all the pipettes were calibrated as per the national standards and exposed to UV light; the door to the extraction room was closed and human movement was restricted, except for authorized persons. The results indicated that the source of the contamination was the master mix room and potentially the master mix cabinet, particularly the ill working internal airflow.

The team got a new laminar flow fitted with a Ultra-violet

light from the hospital administration. The experiment was repeated, and the results were confirmed. The results were also re-confirmed in another laboratory.

### PROGRESS

By mid-August, the laboratory was receiving continuous supply of samples from the different districts of Province 2 and was working in three shifts reaching a testing capacity of up to 600 samples per day. The laboratory adopted a sample pooling strategy with five samples pooled together and only pools that have tested positive were individually extracted while the negative pools were reported as negative samples. The laboratory core team was working on the expansion of human resources and providing training to other staff about biosafety processes and standard operating protocols.

The new laboratory was now part of the national COVID-19 testing chain and was considered a preferred testing centre because of its convenient setup, reliable reporting and skilled staff. thousand positive samples.

### LABORATORY LINKAGE

The laboratory coordinated the sample collection from health facilities, communities, and vulnerable groups. After sample processing, documentation was done using the Information management unit platform, results dispatched by email to Hospital administration, Epidemiology and disease control division (EDCD), Narayani COVID management team, District COVID crisis management centre (DCCMC) and then positive results were dispatched by the District police office, Parsa and District Public health office to all concerned authorities and negative results dispatched to patients via Short Message Service (SMS).

### QUALITY CONTROL

NPHL acts as a reference lab for proficiency testing of COVID-19 PCR tests in Nepal. Five samples per lot were sent to our lab via courier. The samples were processed within 48 hours and the results were dispatched to NPHL within seven days of receipt of PT panel via email. NPHL reported the results as concordant or discordant within 15 days. Our lab results were declared concordant each time the samples were sent.

### LESSONS LEARNED

Following lessons were learnt during the process: 1) Remodel and utilise existing spaces, 2) Cooperate with local and national health experts and equipment manufacturers to solve laboratory issues, 3) Optimally utilize existing human and equipment resources, 4) Create a contamination free space for COVID-19 tests.

### CONCLUSION

Facing the challenges of the current pandemic and

best utilizing them as the opportunity, Narayani hospital laboratory has benefited from establishing a standard molecular laboratory which has utilized human resources and infrastructures within the hospital with empowerment, training and recruitment of the laboratory personnel and information managers. The experience from this scenario can be used in establishing other COVID-19 testing laboratories in minimal resource setting areas of Nepal in the present COVID- 19 peak as well as possible future waves.

## REFERENCES

1. Shrestha R, Shrestha S, Khanal P, KC B. Nepal's first case of COVID-19 and public health response. *J Travel Med* 2020 Apr 27(3):taaa024 [DOI]
2. World Health Organization. Coronavirus disease (COVID-19) Situation Report – 179 [Internet]. 2020 Jul 17 [cited 2021 May 04]. p. 18. [Google Scholar]
3. National Public Health Laboratory. Interim guidelines for SARS-CoV-2 PCR laboratories in National Public Health Laboratory Network, Nepal. Kathmandu: National Public Health Laboratory; 2020. p. 1. [Full text]
4. Birgunj Metropolitan City. Brief Introduction [Internet]. Birgunj: Birgunj Metropolitan City; 2021 [cited 2021 May 04]. Available from: <https://birgunjmun.gov.np/en/node/194>
5. Consulate General of India. About Birgunj [Internet]. Birgunj: Consulate General of India; c2021 [cited 2021 May 04]. Available from: <https://www.cgibirgunj.gov.in/page/page/detail/1>