

# An Efficient DC-AC Power Integration Model for Single-Phase Systems, Simulated in MATLAB

Supriya Pandeya<sup>1,\*</sup>, Menaka Karki<sup>2</sup>

<sup>1</sup>Department of Electrical Engineering, Western Region Campus, Lamachaur Pokhara, Nepal,  
Supriya.762540@pasc.tu.edu.np

<sup>2</sup>Department of Electrical Engineering, Western Region Campus, Lamachaur Pokhara, Nepal,  
Menaka@wrc.edu.np

---

## Abstract

In the face of growing clean energy demands, this study presents a model for integrating Direct Current (DC) sources into the existing Alternating Current (AC) grid. The model is based on a single-phase system where a DC source is added. A converter, designed using the synchronous reference frame, is proposed to address integration issues. This converter allows for the control of both active and reactive power using a dq reference frame. A Proportional-Integrator (PI) controller is chosen for this purpose. To generate the necessary operational references, a Phase-Locked Loop (PLL) is used. An LCL filter is also incorporated based on its performance quality. The entire model is simulated in MATLAB and the output obtained confirms the model's ability to control both active and reactive power when integrating DC with AC and T. This work significantly contributes to the efforts of integrating clean energy into our existing grid systems.

*Keywords:* Ensemble, phase loop lock, d-q frame, synchronous reference frame, MATLAB, Integration

---

## 1. Introduction

The increasing global demand for energy, coupled with the urgent need to reduce carbon emissions and mitigate the impacts of climate change, has underscored the critical importance of renewable energy. As finite fossil fuel reserves dwindle and their continued use exacerbates environmental issues, renewable energy sources such as solar, wind, and hydro power offer sustainable and environmentally friendly alternatives. Harnessing renewable energy not only has the potential to meet global energy needs, but also contributes to energy security, reduces dependence on fossil fuels, and promotes economic growth and job creation. Moreover, renewable energy technologies can play a pivotal role in providing access to affordable, reliable, and clean energy, particularly in remote and rural areas (Anon., 2015). However, the transition to renewable energy requires concerted efforts at all levels - from policy and regulatory frameworks that incentivize renewable energy development, to research and innovation in renewable energy technologies, and public awareness and engagement (Anon., 2015). This introduction underscores the pressing need for renewable energy and sets the stage for a comprehensive discussion on the opportunities and challenges in this field.

As per Annual Report of NEA 2023, The Government of Nepal (GoN) has embarked on a significant initiative, the Grid Solar Energy and Energy Efficiency Project (GSEEP). This project is primarily financed by a credit from the World Bank (WB), amounting to 130 million USD, under IDA Credit No. 5566-NP (Project ID P146344). In addition to this, the GoN has also contributed 8 million USD as counter financing. The GSEEP aims to harness solar energy and enhance energy efficiency in Nepal, marking a crucial step towards achieving the country's sustainable development goals (Anon., n.d.). This demands more advancement and research in field of controller

Converting the direct current (DC) power produced by solar panels into alternating current (AC) electricity that is compatible with home grids is a significant difficulty for residential solar photovoltaic (PV) systems. In this conversion process, single-phase inverters are essential, but they need to be optimized for

dependability and efficiency. A concerted examination of single-phase voltage controllers is required to address this. Among various challenges optimized control can be one of major challenge (R. Šul, No. 1-2 (2008),). "Following-error" is produced by the non-linear time invariant control technique. The power converter can be run at a high switching frequency to minimize the "following error." However, substantial switching losses result in reduced efficiency. There are various difficulties in integrating DC power sources, including solar photovoltaic (PV) systems, into the grid. These comprise problems with voltage and angular stability, reactive power support, fault ride-through capabilities, and power quality (R. Šul, No. 1-2 (2008),). Renewable energy sources' sporadic nature also presents operational and technological difficulties, which reduces network stability and dependability. Along, with that it is difficult to gain THD within IEEE standard (R. Šul, No. 1-2 (2008),)

The project applies Synchronous Reference Frame Theory (dq), which converts AC signals into DC quantities inside a synchronous rotating frame, to address the error problem and to acquire controller within IEEE standard. Notably, single-phase systems cannot directly benefit from the application of dq transformation. The original single-phase AC signal must be converted into an orthogonal signal with a 90-degree phase difference as a workaround. Even in single-phase situations, the dq transformation can be accomplished by employing these two signals to acquired expected output.

## 2. Methodology

The block diagram represents a typical setup for a grid-tied DC power source. This include chronological order of the process.

- **DC Source:** This is the origin of the power, which could be a solar PV array, a battery, or any other DC power source. The DC power from this source needs to be converted to AC power to be compatible with the grid. DC source is considered of 400V
- **Converter:** The DC power from the source is fed into a converter, typically an inverter. The inverter's job is to convert the DC power into AC power. The output of the inverter is provided to the filter.
- **LCL Filter:** After the inverter, the high-frequency AC signal passes through an LCL filter. This filter is designed to remove the high-frequency harmonics produced by the switching operation of the inverter. The result is a cleaner, sinusoidal AC signal that is suitable for injection into the grid.
- **Utility (Grid):** Finally, the filtered AC power is fed into the utility grid. The grid could be a local microgrid or the main electrical grid. An AC source of 325 Volt of 50Hz is considered for the simulation purpose.

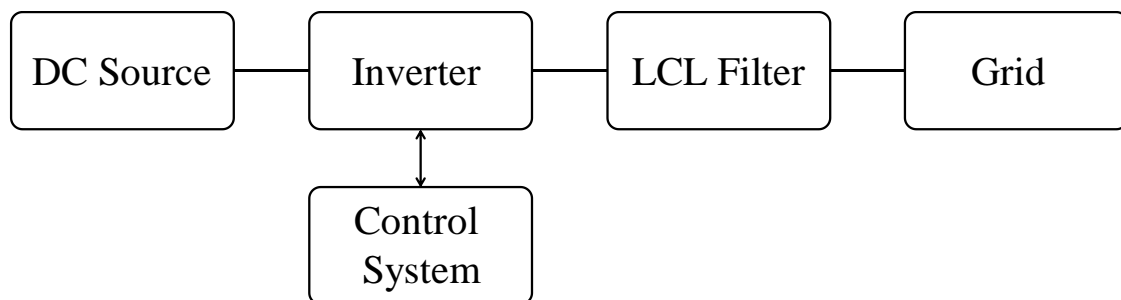

Figure 1. Block Diagram of Proposed Work

This setup allows for the efficient conversion and filtering of DC power for use in an AC grid. The LCL filter is a crucial component that ensures the quality of the power fed into the grid, minimizing harmonic distortion and improving overall system performance. The exact design and control of each component can vary depending on the specific requirements of the system.

## 2.1 Design of LCL

For the single-phase system, LCL filter is designed to remove the harmonics and to enhance the power quality of the system (K. Hyosung, 2008. ICSET 2008.). For this model, LCL filter is used where  $L_1$  is inverter side filter,  $L_2$  is grid side filter and a capacitor  $c$  is used. Capacitor is designed based upon the reactive power absorbed at rated condition. Usually, reactive power absorbed by capacitor limited to 5% of the rated power(S). The reactive power is given by;

$$Q = \frac{V^2}{\left(\frac{1}{2 \cdot \pi \cdot f \cdot C}\right)} \quad \text{Equation (1)}$$

Where,  $Q$  is reactive power

$f$  is frequency,

$C$  is the capacitance of the capacitor used as filter,

$V$  is the voltage of the grid,

Using equation (1), value of capacitance is obtained. After that, value of both inductors is obtained. In order to gain the value of inductor connected to inverter side( $L_1$ ) maximum permissible ripple current is set. Based upon review, current ripple is limited to 20% and value of inductor is gained. Inductor is given by;

$$L_1 = \frac{V_{dc}}{4 \cdot f_{sw} \cdot \Delta I_{ppmax}} \quad \text{Equation (2)}$$

Where,  $V_{dc}$  is DC side voltage

$f_{sw}$  is switching frequency,

$\Delta I_{pp}$  is current through the inverter,

Equation (2) is used to get the value of inductor  $L_1$ , which comes out to be 4.06 mH. It is therefore necessary to make sure that the maximum voltage loss does not above 10% of the rated capacity in order to determine the value of the inductor connected on the grid side. As a result, it is determined that the grid side inductor is 4.85 mH.

After the right inductors and capacitors are chosen for the filter, a verification procedure is carried out, depending on the resonance frequency. It is found that the obtained resonance frequency stays below 0.5 times the switching frequency but surpasses 10 times the grid frequency. This confirms that the inductor and capacitor values listed are appropriate for the suggested single-phase model, supporting the filter's design.

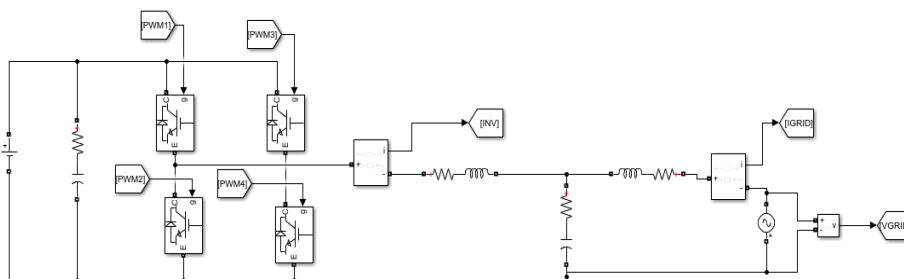

Figure 2. Proposed Model with LCL filter

## 2.2 Proposed system Control strategy

Cascaded control loop structures are used in the control system to operate the inverter when linked to the grid. The current-controlled mode of operation is the inverter's primary function. The inner control loop, which is in charge of carrying out the present control, is in charge of this mode. Power control, however, is

the responsibility of the outer loop. It offers the capacity to regulate both reactive and active power. Either directly, by providing reference values, or indirectly, by controlling the DC link voltage, this control can be accomplished. In this configuration, the inverter's active power output is managed by the DC link voltage regulation. This technique has some adaptability and flexibility, which makes it useful for a range of applications outside of photovoltaic systems. When the inverter is connected to the grid, it ensures optimal performance and efficient operation through precise control over power output. The goal of this control method is to adjust the current output to the grid in accordance with the power demand that the outer control loop specifies.

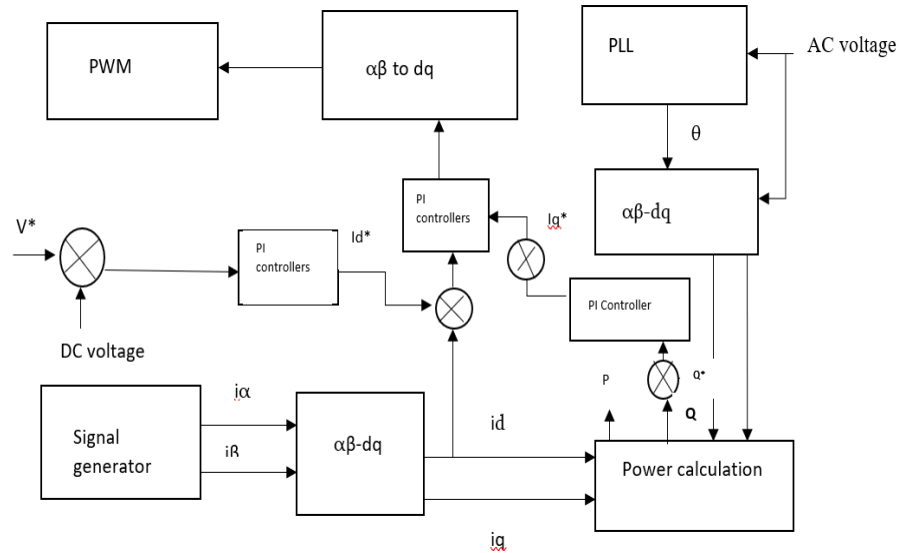

Figure 3. Control Strategy

For the operation of power devices like PV inverters that feed power into the grid, the utility's phase angle is vital information. A phase-locked loop is a closed-loop system where a feedback loop is used to regulate an internal oscillator to maintain the time and phase of an external periodic signal (M. Ciobotaru, 2006).

When sending current to the grid is necessary, phase-locked loop (PLL) is utilized to create reference current. PLL generates current that is in phase with the source voltage to control the active power and generates current that is out of phase with the main current to regulate the reactive power. Next, a PLL for the model was constructed, providing grid output in order to eliminate harmonics (Xinbo Ruan, 2017.)

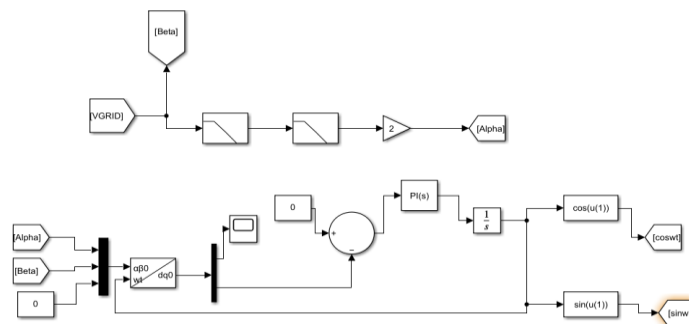

Figure 4. Phase Loop Lock

### 2.3 Synchronous d-q Frame

The inability of proportional-integral (PI) controllers to attain zero steady-state error is a significant obstacle when attempting to control time-varying signals, such as sinusoidal currents and voltages. The synchronous

reference frame can be used to represent time-varying signals as DC signals in order to get around this problem. The fundamental idea is that a phasor revolving at an angle of  $\omega$  seems stationary in relation to a reference phasor rotating in the same direction at the same angular velocity of  $\omega$  (S. Golestan, 2016). For time-varying three-phase signals, the Clarke transformation—also referred to as the conversion from a three-phase natural frame to the Stationary Reference Frame—is used.

For efficient signal control, the Stationary Reference Frame must be converted to the Synchronous Reference Frame. Even though a three-phase signal can be split into two quadrature phases, the resulting signals' rotational frequency remains close to that of the original three-phase vectors. These signals cannot be used with proportional-integral (PI) controllers since they will not result in zero steady-state error.

To create the PWM signals for IGBT switching, the reference voltage signal produced by the current control loop is compared to a triangular carrier waveform. The necessary inverter output voltage waveform is formed by these signals. In order to avoid non-zero steady-state error, the control is implemented in the dq reference frame (S. Golestan, 2016). But a phase-locked loop (PLL) is used to make sure the dq frame converted signals stay in sync with the grid. This PLL continuously monitors the grid voltage's phase. The PLL's phase ( $t$ ) of the grid voltage is necessary to carry out the dq transformation and the inverse transformation.

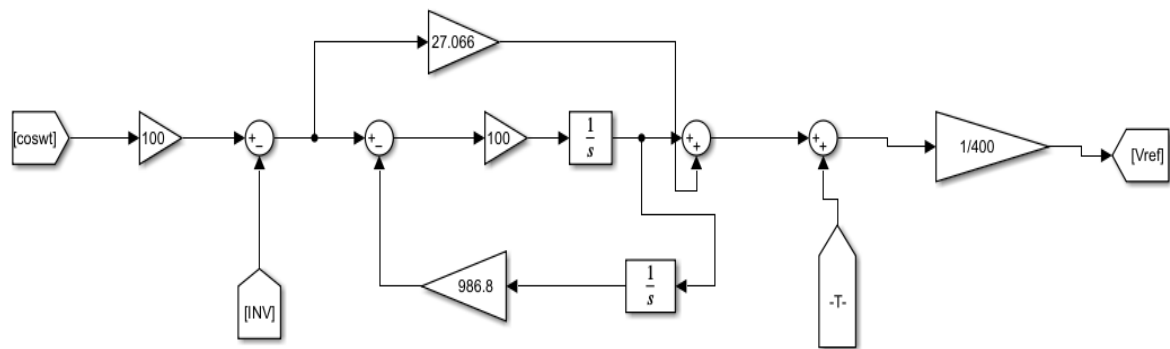

Figure 5. Current Controller

## 2.4 PWM Generator

Two sine-wave reference signals are required in order to perform unipolar pulse width modulation. The amplitude and frequency of these signals should be the same, but they should be 180 degrees out of phase with one another (Ali Algaddafi, 2016). Two pulse width modulation (PWM) signals are then created by comparing these signals to a triangle carrier waveform. In a full bridge circuit, the upper left and upper right switches are controlled by these two PWM signals, while the lower left and lower right switches are controlled by their inverse signals. It is imperative to guarantee that neither of the switches on one leg of the bridge is ever turned on at the same time [11]. Should this occur, a short circuit would be formed across the DC voltage source, perhaps resulting in an excessive current. A short circuit across the DC voltage source could cause overcurrent and damage to switches. The circuit's insulated gate bipolar transistors (IGBTs) cause a tiny delay or "dead band" while switching on and off the same leg. This assures safe and effective operation of the circuit (Ali Algaddafi, 2016). The controller generates a reference voltage, which is then sent to the PWM generator to alter the carrier signal.

Unipolar modulation uses both positive and negative signals, with comparators comparing the reference and regenerated signals. Model of the PWM Generator.

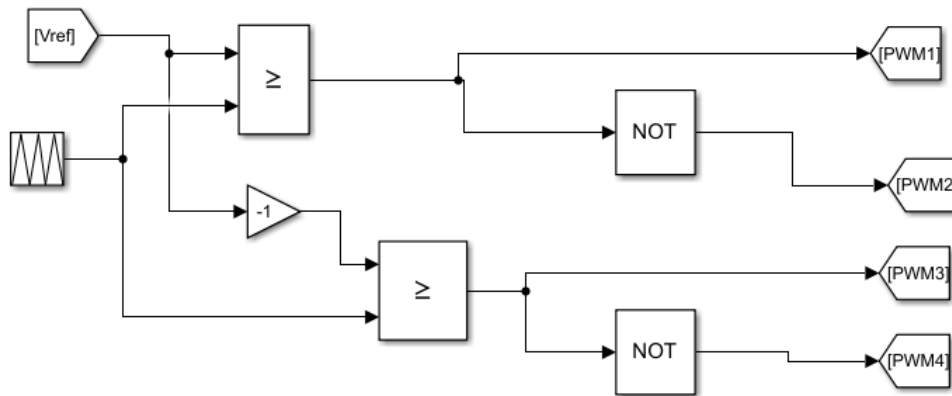

Figure 6. PWM Generator for converter

### 3. Simulation and Results

To validate the proposed system, a model is designed in MATLAB Simulink. The model includes an AC source representing the grid and a DC source connected to the system. An LCL filter is also incorporated into the model, along with all other necessary components. Two scenarios are examined in the simulation.

The simulation results provide valuable insights into the system's performance under different conditions and validate the effectiveness of the proposed control scheme. These results contribute to a better understanding of the dynamics of grid-connected DC power sources and inform the design of more efficient and reliable power systems. Further analysis and discussion of the simulation results will be presented in the following sections. In order to conduct study of outer control strategy for active power control, following model is considered; In the given system, an AC source with a voltage of 230 volts and a frequency of 50 Hz is connected to a DC voltage source of 400 volts through a converter.

Table 1. Parameters of Model

Parameter	Value
Vdc	400V
Vgrid	230V
P0	2kVA
Filter Capacitor	4.03microfarad
Grid Side Inductor	4.07Mh
Inverter Side Inductor	4.03Mh
Switching Frequency	10kHz
Resonance Frequency	1416Hz
Irip	20% of rated current

This converter implements the Synchronous Reference Frame Theory for control, and includes both a Phase-Locked Loop (PLL) and a current controller. The output of the grid voltage is obtained in such a way that it is in phase with the grid current. This implies that the system is operating under unity power factor conditions, which is highly desirable in power systems. Under these conditions, the real power and apparent power are equal, meaning that all the power supplied by the source is available for use in the load. This results in maximum power transfer and increased efficiency of the system. The use of a converter with Synchronous Reference Frame Theory allows for better control of the power flow in the system. The PLL and current controller contribute to maintaining the stability of the system, ensuring that the voltage and current waveform

are aligned, and that the current follows the reference current closely. This is crucial for the reliable and efficient operation of power systems, particularly in systems that integrate both AC and DC sources.

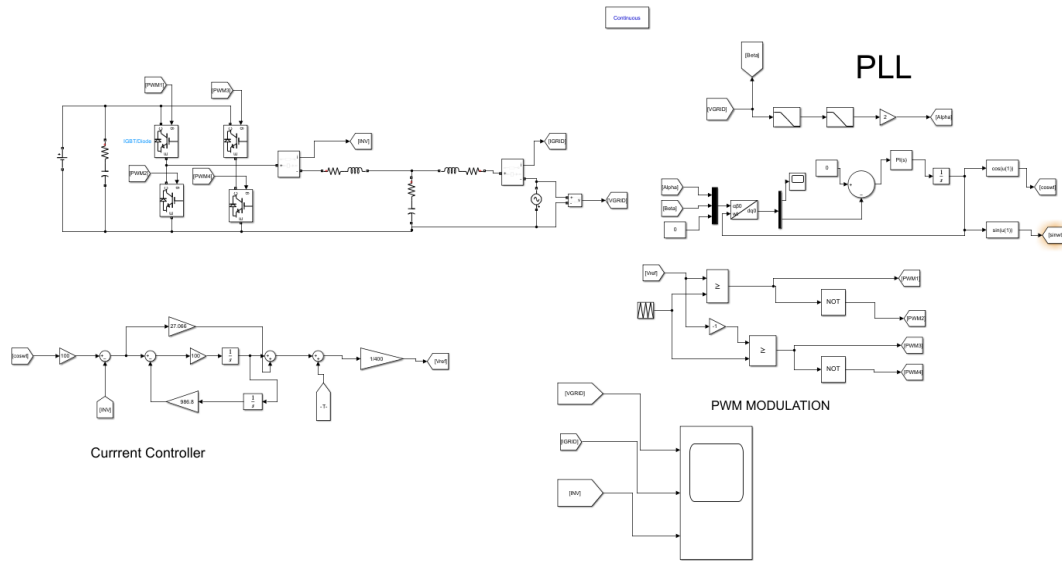

Figure 7. Simulated Model of Proposed work

The simulation results for the converter connected to the grid under pure resistive load and no load are shown. As previously stated, the reference current  $I^*$  regulated the active power and the reactive power at zero value. The grid voltage and output converter current are shown to be in phase in the figure below, indicating that the control algorithm has satisfied the requirement that the reactive power have a zero value.

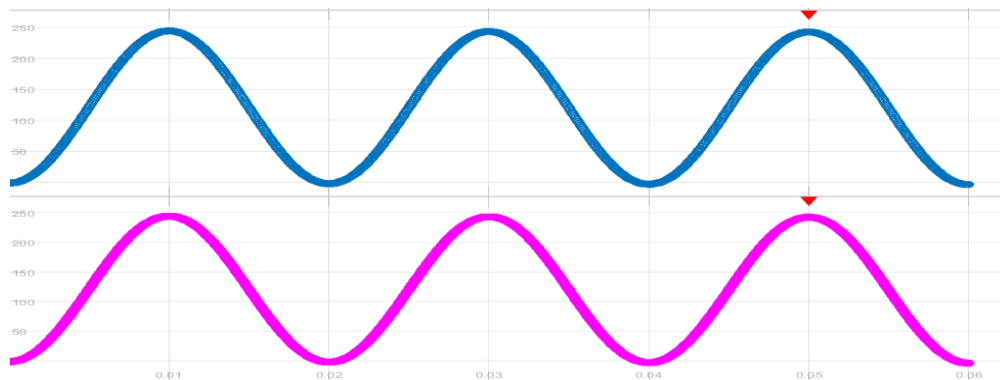

Figure 8. Grid Current and Converter current

The next simulations figure shows the reference  $I^*$  current step changes and the calculated THD value. The grid and the loaded converter were first connected. In  $I^*$ , the nominal current value was adjusted in steps of 0.8 to 0.5. The converter currents mostly satisfied the load's requirements after synchronization and transients. The current is divided between the load and the grid after a step change, with the load receiving the residual current. It is evident that the transients are compensated for a period of two, and that the current's THD (which is equal to 3.15%) fits the necessary conditions (P. Cernan, 2013).

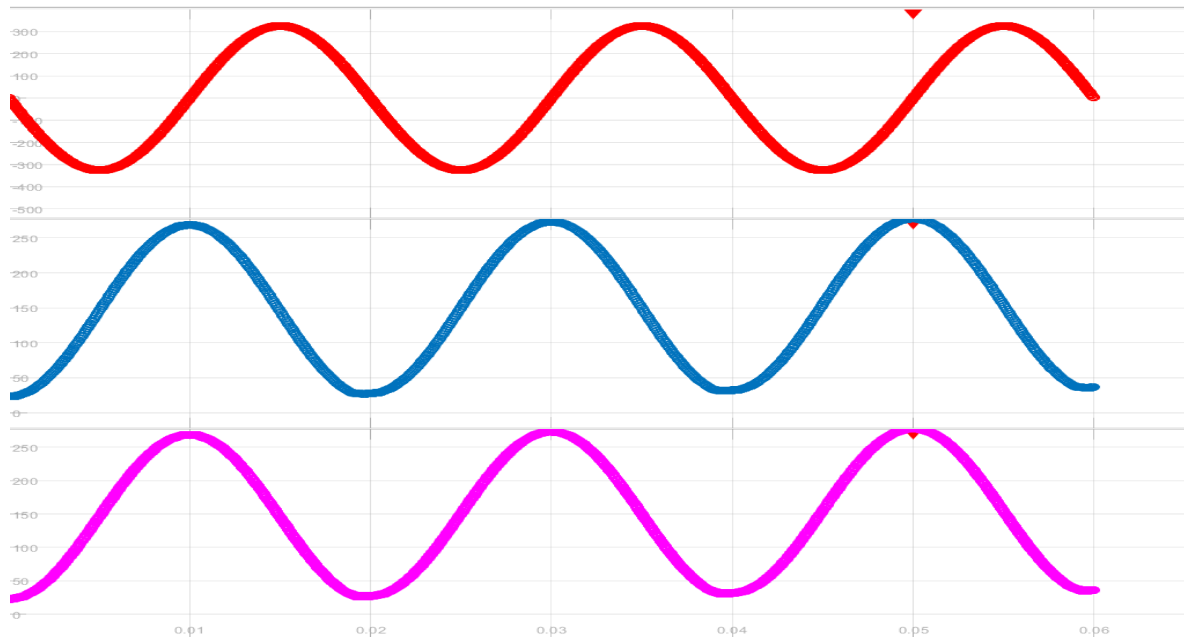

Figure 9. Grid, converted and load current of grid and converter showing

#### 4. Discussion

The discussion focuses on the integration of Direct Current (DC) sources into the established Alternating Current (AC) grid, a pivotal move towards meeting the escalating demand for sustainable energy. The proposed model in this study centers on a single-phase system augmented with a DC source. To tackle integration challenges, a converter is devised using synchronous reference frame methodology. This converter facilitates active and reactive power control through a dq reference frame, employing a Proportional-Resonant (PR) controller.

Furthermore, the model includes a Phase-Locked Loop (PLL) for generating operational references and an LCL filter renowned for its (P. Cernan, 2013) performance reliability. MATLAB simulations validate the model's capability to manage both active and reactive power during DC-AC integration. This research significantly contributes to the endeavor of incorporating clean energy into existing grid infrastructures. However, while the model demonstrates control over active and reactive power, additional research and refinement are necessary to optimize this control mechanism and address potential real-world challenges. Future investigations may explore the integration of alternative renewable energy sources and the implementation of advanced control strategies to bolster grid stability and reliability.

#### 5. Conclusion

The analysis of the simulation results takes into account both the pure resistive load and the no-load condition of the grid-connected converter. It is noted that the reference current maintains the appropriate level of active power and zero reactive power. Grid voltage and converter output current alignment verifies that the control algorithm successfully maintains zero reactive power, guaranteeing stable operation and effective power transfer. The grid linked converter and its control algorithm are presented in this study. In addition to explaining the synchronization method created by the PLL structure, this article looks into how the grid voltage ripple affects the SOGI. It may be concluded that the quadrature voltages,  $v_\alpha$  and  $v_\beta$ , remained undistorted and that the ripple voltage had no effect on the SOGI function. Additionally, the simulation results demonstrate that the reactive power is maintained at zero and that the currents fulfill the specified conditions, with THD remaining below 5% throughout the whole operating range.



In order to improve grid stability and reliability, future research could examine the integration of more renewable energy sources and the application of sophisticated control techniques. To sum up, our study offers a reliable and effective method for controlling the active and reactive power in grid-connected DC power sources, greatly advancing efforts to incorporate clean energy into current grid systems.

### **Acknowledgements**

The author would like to express their gratitude to the KEC Conference 2024 for granting them the valuable opportunity to publish paper. Additionally, the authors extend sincere thanks to Assistant Professor Menaka Karki for her invaluable support in successfully concluding this research within a challenging timeframe, a contribution that is deeply appreciated.

### **References**

- Ali Algaddafi, K. E. A. M. a. A. E., 2016. Comparing the performance of bipolar and unipolar switching frequency to drive dc-ac inverter..
- Anon., 2015. Advantages of using matlab simulinkProcedia - Social and Behavioral Sciences., p. :179–184.
- Anon., n.d. Nepal Electricity Authority.. Annual Report, t, 2023.. *Annual Progress of Fiscal year 79/80.*
- Das., S. T. K. a. G. T., 2007. Simulation of dq control system for a unified power flow controller.. *ARPN Journal of Engineering and Applied Sciences.*, pp. 10–19,.
- Hirofumi Akagi, Y. K. a. A. N., 1984.. Instantaneous reactive power compensators comprising switching devices without energy storage components. *IEEE Transactions on Industry Applications, IA-20(3)* , pp. :625–630,.
- K. Hyosung, K. K.-H., ,2008. ICSET 2008.. “Filter design for Grid Connected PV Inverters”, in: Sustainable Energy Technologies., *IEEE International Conference*, Issue p. 1070- 1075, pp. p. 1070- 1075.
- M. Ciobotaru, R. T. F. B., 2006. “A New Single-Phase PLL Structure Based on Second Order Generalized Integrator”. *IEEE Power Electronics Specialists Conference.*, Issue 37.
- N. Mohan, M. U. a. W. R., 1995. , Power Electronics. Tata. Mc Grawell.
- P. Cernan, B. D., 2013. “*Optimization of Efficiency of Dual Flyback Inverter for Photovoltaic Applications Using Silicon Carbide Devices*”. s.l., s.n.
- R. Šul, P. F. M. F., No. 1-2 (2008),. “Analysis of PMMT operation for renewable (PV/FC) energy source”, in: Advances in electrical and electronic engineering. -. Volume Vol. 7, pp. . 103-105..
- S. Golestan, J. M. G. a. G. B. G., 2016. Five approaches to deal with problem of dc offset in phase-locked loop algorithms: design considerations and performance evaluations.. *IEEE Transactions on Power Electronics*, pp. 31:648–661,.
- Shafiullah, M., Ahmed, S. D. & Al-Sulaiman, F. A., 2022. Grid Integration Challenges and Solution Strategies for Solar PV Systems: A Review. *IEEE Access*, Volume Vol. 10, pp. 52233 - 52257.
- X. Ruan, X. W. D. P. D. Y. W. L. a. C. B., 2018. Control Techniques for LCL type of Filters. *Springer Signapore* .
- Xinbo Ruan, X. W. D. P. D. Y. W. I. a. C. B., 2017.. Control Techniques for LCL-Type Grid-Connected Inverters. Issue 08.