



# VAR Compensation on Load Side using Thyristor Switched Capacitor and Thyristor Controlled Reactor

Bibek Bimali <sup>a</sup>, Sushil Uprety <sup>b</sup>, Ram Prasad Pandey <sup>c</sup>

*Department of Electrical Engineering, Pulchowk Campus, Institute of Engineering, Tribhuvan University, Nepal*

Corresponding Authors: <sup>a</sup> bbekbimali@gmail.com, <sup>b</sup> sushilupt20@gmail.com, <sup>c</sup> rampajwol@pcampus.edu.np

Received: 2020-08-31

Revised: 2021-03-21

Accepted: 2021-03-23

## Abstract:

Generally, AC loads are the inductive loads which are reactive in nature. These loads, thus, demand and draw reactive power from the supply source. If these loads draw large lagging current from the source, this will cause excessive voltage drop in the line, which can even cause the voltage collapsing in the line itself if the drop in the line is excessively high. VAR compensation means efficient management of reactive power locally to improve the performance of AC power systems. In this paper, Static VAR Compensator, using TSC (Thyristor Switched Capacitor) and TCR (Thyristor Controlled Reactor), is designed and simulated in MATLAB to maintain the power factor of power system nearly to unity at all times. TSC and TCR are basically shunt connected capacitors and inductor respectively whose switching (of capacitors) and firing angle control (of inductor) operations are carried out using thyristors. The purpose of capacitors is to supply lagging VAR as per the demand by the connected loads and the overcompensation due to excess VAR generated by the discrete set of turned on capacitors are absorbed by the adjustable inductive reactance of the inductor in TCR branch through firing angle control mechanism.

**Keywords:** Static VAR Compensator (SVC), Thyristor Switched Capacitor (TSC), Thyristor Controlled Reactor (TCR), Firing Angle

## 1. Introduction

The voltage and frequency at each supply point would be steady and free from any unwanted harmonics in an ideal ac electrical power system, and the power factor would be constant at unity all the time. Ideally, these parameters would be independent of the sizes and characteristics of consumers' loads in the distribution side. In such ideal scenario, the consumers' loads to be connected are planned and arranged so as to match perfectly with the supply voltage and frequency at all times. Besides, there would be no intrusion between different loads as the result of disparities in the current taken by each one. However, practically, we find irregularities in the power system due to various factors: focusing mainly on ever changing loads in distribution side and also the connected large passive loads, which can deteriorate the quality of supply. The quality of supply, however, can be improved by the installation of large capacitor banks in consumers' side. The

improvement can be made more efficient and sustained by providing flexibility to the operation of the capacitor banks using TSC and TCR [1].

The harmful effects of non-linear loads in the power system can be compensated dynamically by using different compensation schemes and procedures. However, such compensation should not alter the source signal quality significantly [2, 3]. Improved power factor, reduced harmonic content and improved distribution line losses can be some of the major gains while using various compensation techniques. The compensator is more effective and, undeniably more economical in industries because of the dynamic behavior, which is significant, of the inductive loads. The compensator should be nicely adapted to the load changes. Unfortunately, the practices normally used for compensation are based on circuit controllers that distort the waveform of the signals subjected to the control. In such instances, static compensator can prove to be a better alternative which must achieve power

factor improvement, harmonics elimination, reactive power compensation and energy saving. Though the static compensator is broadly used and considered under sinusoidal voltage situations, waveforms equivalent to the controlled current present high harmonic content [2].

A parallel arrangement of thyristor controlled reactor and fixed shunt capacitor makes a static VAR compensator as shown in figure 1. The thyristor switch is used in the SVC to convert a fixed inductor into a variable one. In fact, voltage across inductor can be controlled by varying firing angle of the thyristor and so the current flowing through the inductor. In this way, the overly compensated reactive power by the fixed capacitor can be made to be consumed by the inductor in a controlled manner.

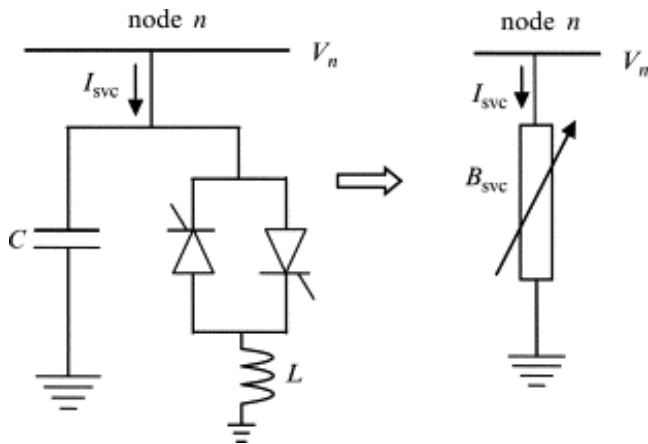

**Figure 1:** Static VAR Compensator

The SVC is capable of step-less adjustment of reactive power over an unlimited range without any time delay [4]. It improves the system stability and power factor. Static VAR compensator has no rotating parts and is employed for surge impedance compensation and compensation by sectionalizing a long transmission line. The use of thyristor switched fixed capacitors as VAR compensator can sometimes overcompensate the reactive power demand by the inductive loads which may result to the leading power factor that is not desired [5, 6]. So, in this paper, SVC is designed using discrete sets of TSC and a TCR. This helps to reduce maximum variations of firing angle of thyristor in TCR branch and thus minimizes harmonics in system current. Some attempts have been previously carried out in light of the aforementioned problems introduced by supplying large reactive power to the loads from the source alone. A typical TSC scheme has been applied

to supply the lagging VAR to the inductive loads from the locally installed capacitor banks [7]. However, only applying the TSC scheme might result to the overcompensation of the reactive power demand by the loads causing the leading of power factor. Therefore, recent works that incorporate both TSC and TCR schemes that use the hardware-based microcontroller/Arduino which requires signals to be transferred to the digital form to fire-up the thyristors to prevent leading power factor and maintain near about unity power factor have been put forward [8]. In this paper, however, we have tried to do the similar experiment by using the PID controller (and analog electronics) to control the firing angle of the thyristors and also testing for the effectiveness of the proposed simulation for the loads varying continuously with the time.

## 2. Static VAR System

In traditional methods of shunt compensation, inductors are connected in parallel as loads during lightly- loaded conditions and shunt capacitors are connected during heavily loaded conditions in order to maintain constant load operation. These methods do not offer much flexibility for load variations to the consumer side and furthermore, it takes longer time for the employed circuit breakers to perform regular switching operation and circuit breakers are not suitable for frequent switching during voltage variations [2]. These cons have been appreciably improved by the Static VAR System (SVS). In a static VAR system, thyristors are used as switching devices instead of robust circuit breakers. The thyristor switching is faster than mechanical switching and also it can help reduce the temporary overvoltage due to the transients by controlling the instant switching. These tremendous advantages offered by the advent of thyristors have completely changed the traditional inefficient ways to better, more efficient, and more flexible reactive compensation for optimum EHV/UHV system performance. The static VAR compensators (SVC) use the conjunction and coordination of shunt reactor and shunt capacitor with thyristors of appropriately high ratings for both voltage and current to obtain fast and accurate control of reactive power flow [9]. Some of the commonly used schemes of SVS are briefly explained in following sections.

## 2.1 Thyristor Switched Capacitor (TSC)

Thyristor switched capacitor can be defined as a shunt-connected capacitor with a bidirectional thyristor valves to provide binary switching operation of the capacitor in either complete or zero conduction of the shunted capacitor with the line [2]. This scheme consists of a power capacitor, whose switching is controlled by the series-connected bidirectional thyristor valves, and usually accompanied by an inductor which acts as a current limiting reactor. TSC acts a major components of the TSC-TCR compensation scheme. A number of TSCs are shunted together to the supply line to offer minimum to the maximum reactive power compensation. Static VAR compensators are the members of the Flexible AC transmission system (FACTS) family.

The capacitor can be turned on and off with the safe minimal-transients when the thyristor is switched on and off at the same time instant when the capacitor voltage and the system voltage are at the same voltage level [2, 3]. Static compensators of the TSC type have the properties of stepwise control, average delay of one half a cycle (maximum one cycle) and no generation of harmonics since current transient component can be attenuated effectively. The schematic diagram of the TSC is shown in figure 2.

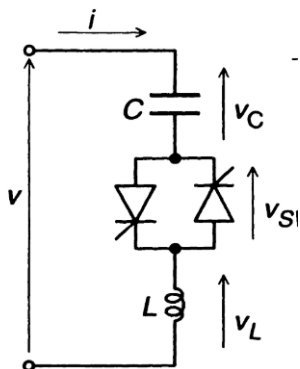

Figure 2: Thyristor Switched Capacitor

## 2.2 Thyristor Controlled Reactor (TCR)

A basic model diagram of single-phase thyristor-controlled reactor (TCR) is shown in Figure 3. It consists of a reactor of fixed inductance  $L$ , and a bidirectional thyristor valve (or switch) as indicated by label 'SW' in Figure 3. Currently available large thyristors are of very high rating capacities: they can withstand voltage up to 4000-9000 volts and conduct

current up to 3000-6000 amperes. During practical application, a number of thyristors (typically 10 to 20) are connected together in series in order to meet the blocking voltage levels criteria at a given power rating plus a factor of safety is included [9]. A series of thyristors with the same polarity are operated all at once to function together as a unit. The valve will automatically block immediately after the ac current crosses zero, unless the gate signal is reapplied.

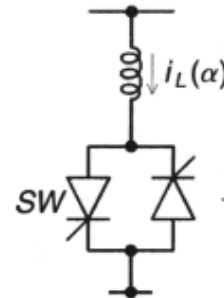

Figure 3: Thyristor Controlled Reactor

The current flow in the reactor can be changed from zero (thyristor valve open) to maximum (thyristor valve closed) and in between any continuous current value by the method of firing delay angle control [2, 3]. That is, the closure of the thyristor valve is delayed with respect to peak of the applied voltage: when the current through inductor in TCR actually starts to conduct, and then the flow of the current is controlled by controlling the conduction time of the thyristor valves. This method of current control is illustrated in Figure 4, where the applied voltage ( $V$ ) and the reactor current  $i_L(\alpha)$  which is lagging behind  $V$  by 90 degrees, which can be considered to be at zero delay angle (switch fully closed) and at an arbitrary  $\alpha$  delay angle, are shown.

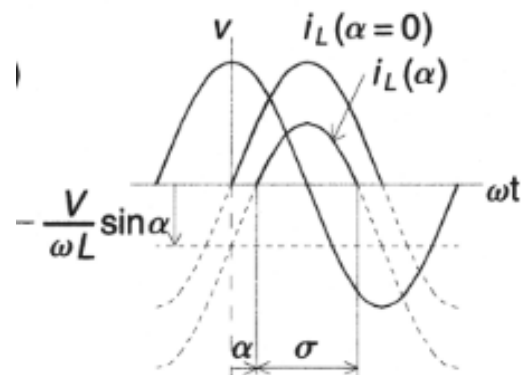

Figure 4: Firing Delay Angle Control

The amplitude  $i_{LF}(\alpha)$  of the fundamental reactor current  $i_{LF}(\alpha)$  can be expressed as a function of angle  $\alpha$ :

$$i_{LF}(\alpha) = \frac{V}{\omega L} \times \left( 1 - \frac{2\alpha}{\pi} - \frac{\sin(2\alpha)}{\pi} \right)$$

### 2.3 Combined TSC and TCR

The above introduced TSC and TCR can be combined together to control the reactive power flow to the loads from the source as shown in figure 5. The separate modules are connected together to offer the best flexibility to the consumers' loads by simultaneously varying the switching of the capacitor banks in discrete number in TSC branch and continuously varying the flow of current in inductor in TCR branch. By coordinating the control between the reactor (which is continuous) and the capacitor steps (which is discrete), it is possible to obtain fully step-less control.

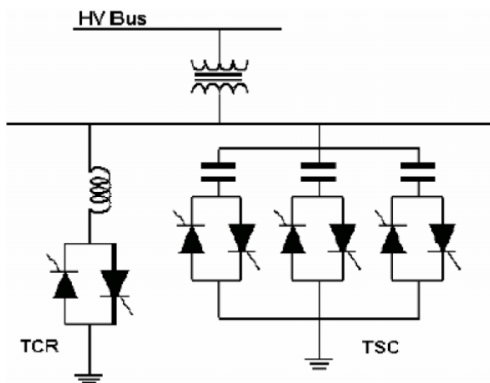

Figure 5: Combined TSC and TCR Configuration

Static compensators of the combined TSC and TCR type are characterized by a continuous control, practically no transients, low generation of harmonics (because the controlled reactor rating is small compared to the total reactive power), and flexibility in control and operation [3]. The disadvantage of the TSC-TCR as compared with TCR and TSC type compensators is the higher cost installation, however, the cost can be reimbursed in no longer time: in the long run, this scheme becomes economical than to pay periodically for the KVA demand charges by the Electricity Authority. A static VAR system provides a fast, smooth and step-less variation of compensation of reactive power injected into the line. It ensures an accurate voltage control of buses over a wide range of loads.

### 3. Design of Static VAR System

The schematic block diagram of the proposed Static VAR System (SVC) is shown in Figure 6.

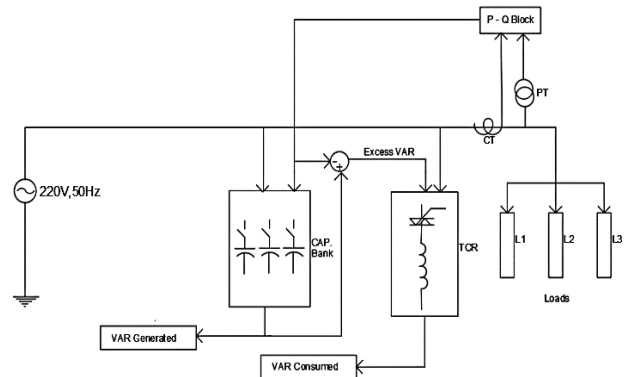

Figure 6: Single phase block diagram of TSC-TCR with the connected loads

The Static VAR compensator has been designed and simulated in MATLAB/SIMULINK. Each of the blocks has been explained below.

#### 3.1 Overall MATLAB Simulation Model

Figure 7 shows the complete SVC Model in MATLAB Simulink. We used 220V, 50Hz supply source and small resistive element of 0.05 ohm is used to denote source and line resistance.

#### 3.2 Varying Load

In this block, three loads each of 5KW, 3KVAR are used. One set of load is initially connected and other two sets of loads are switched on automatically in an interval of 3 seconds and 7 seconds respectively based on ramp signal traveling along with the real time. Figure 8 shows the Varying Load block.

#### 3.3 Capacitor Bank Block

Figure 9 shows the Capacitor Bank Block. In this block, five capacitor units each generating 2KVAR. The required KVAR for the loads is divided by the KVAR value of single capacitor unit used. The whole number just succeeding the obtained fractional value (except for the exact multiple of the capacitor unit value) is the number of capacitor units to be switched on. This will cause overcompensation if the required VAR is not exact multiple of one single capacitor unit.

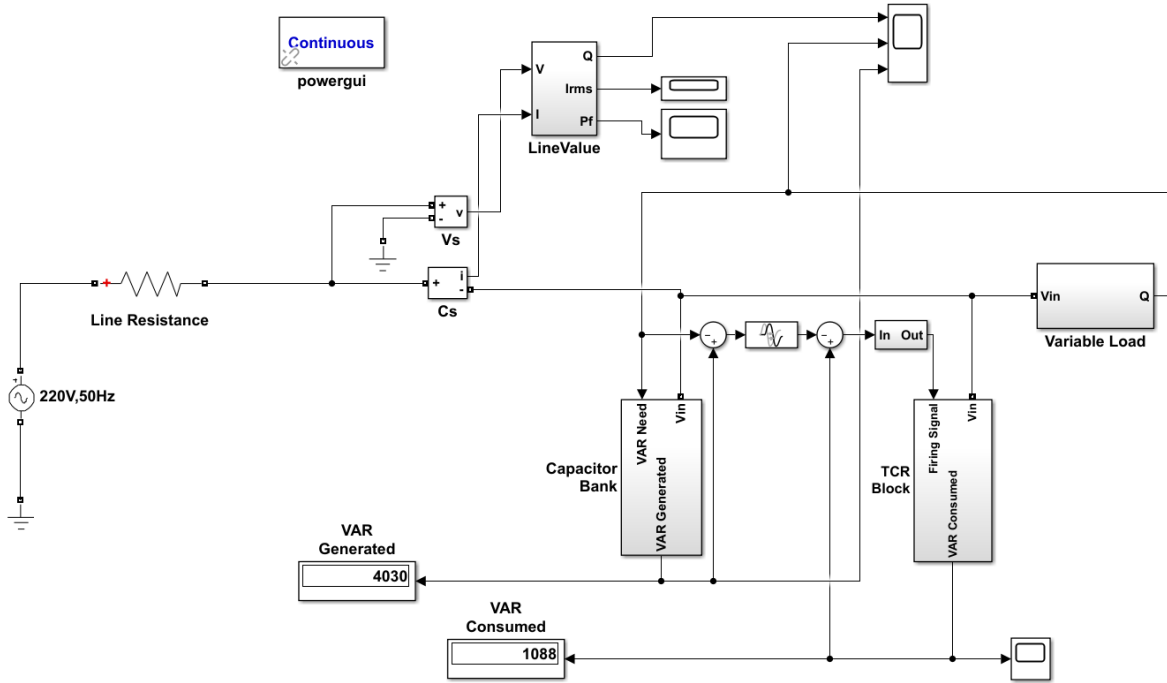

Figure 7: SVC Model in MATLAB Simulink

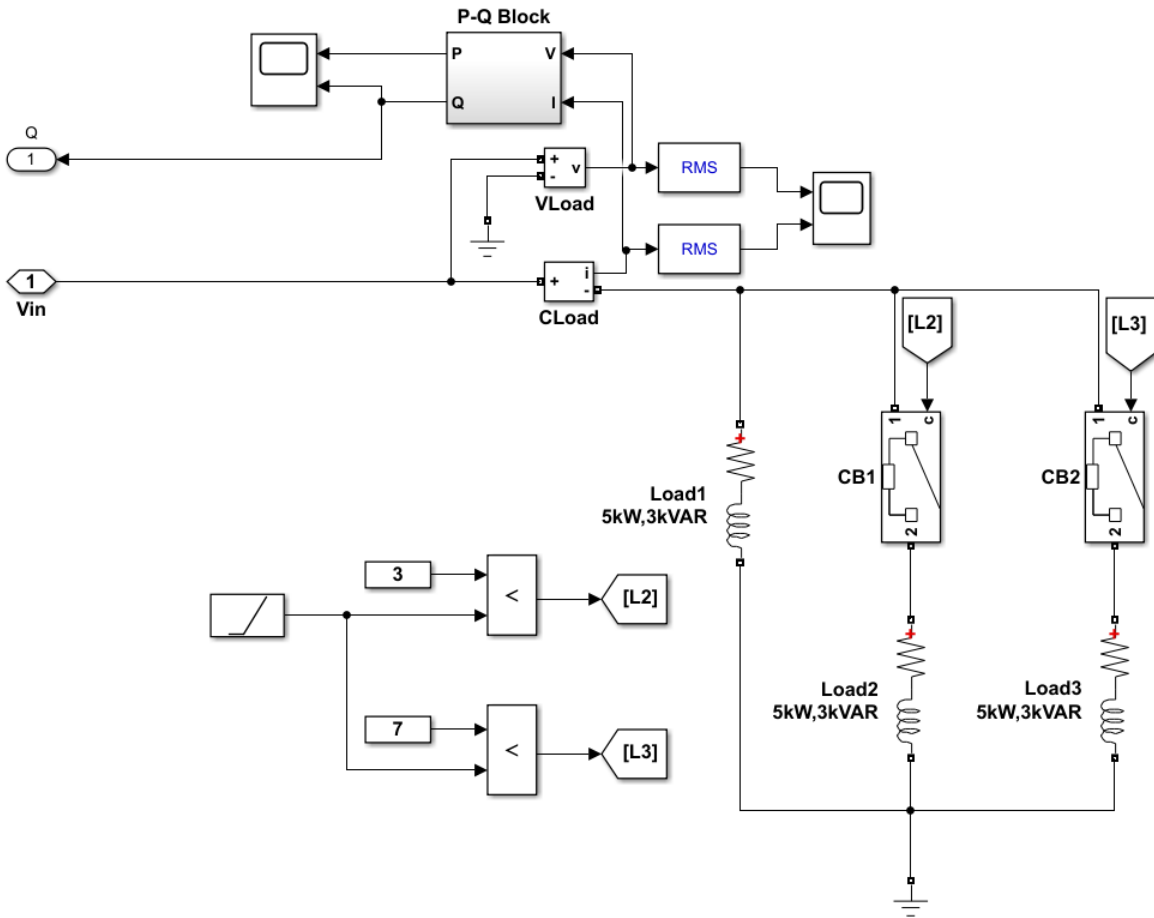

Figure 8: Varying Load used in MATLAB

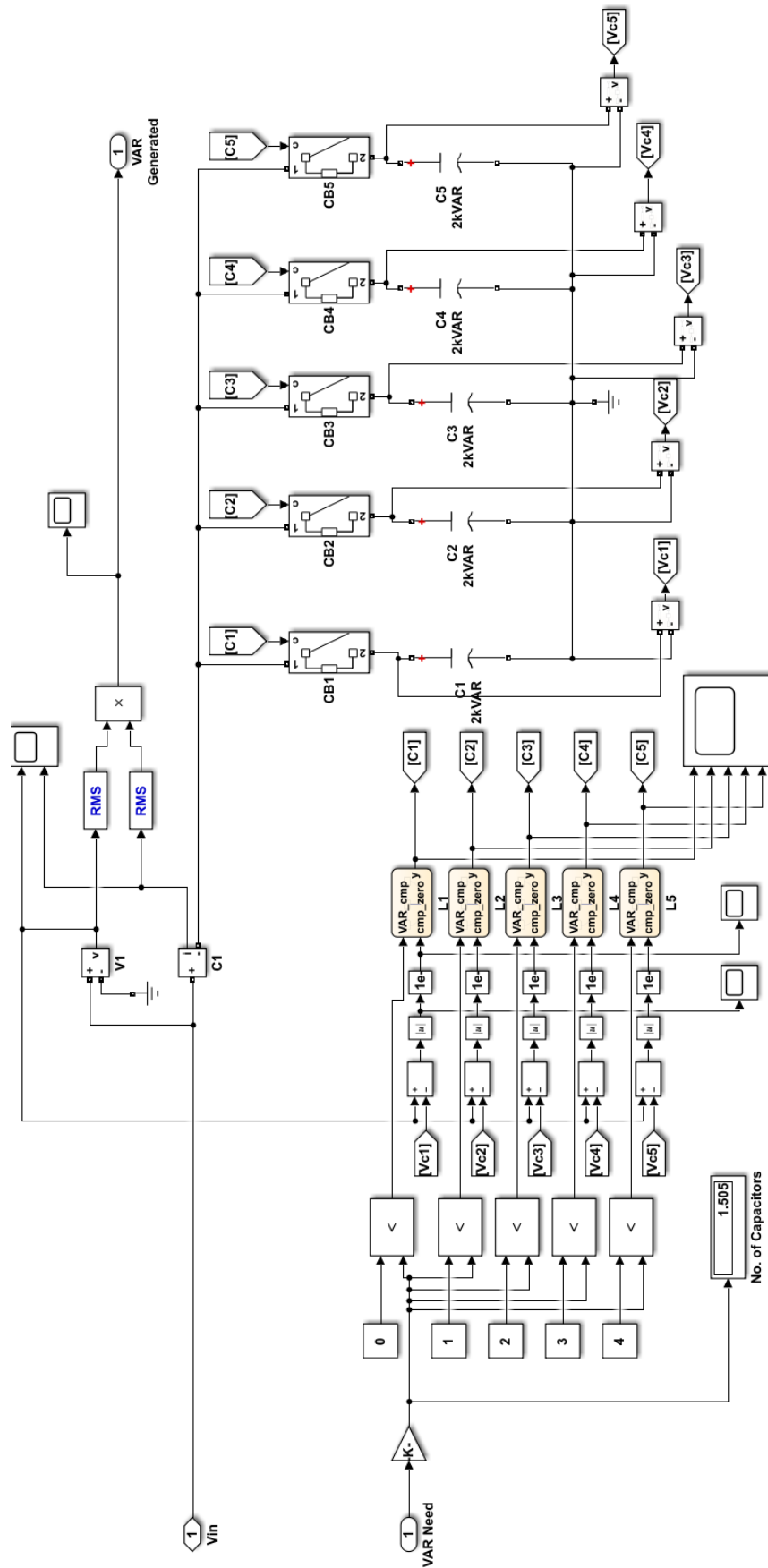

Figure 9: Capacitor Bank Block

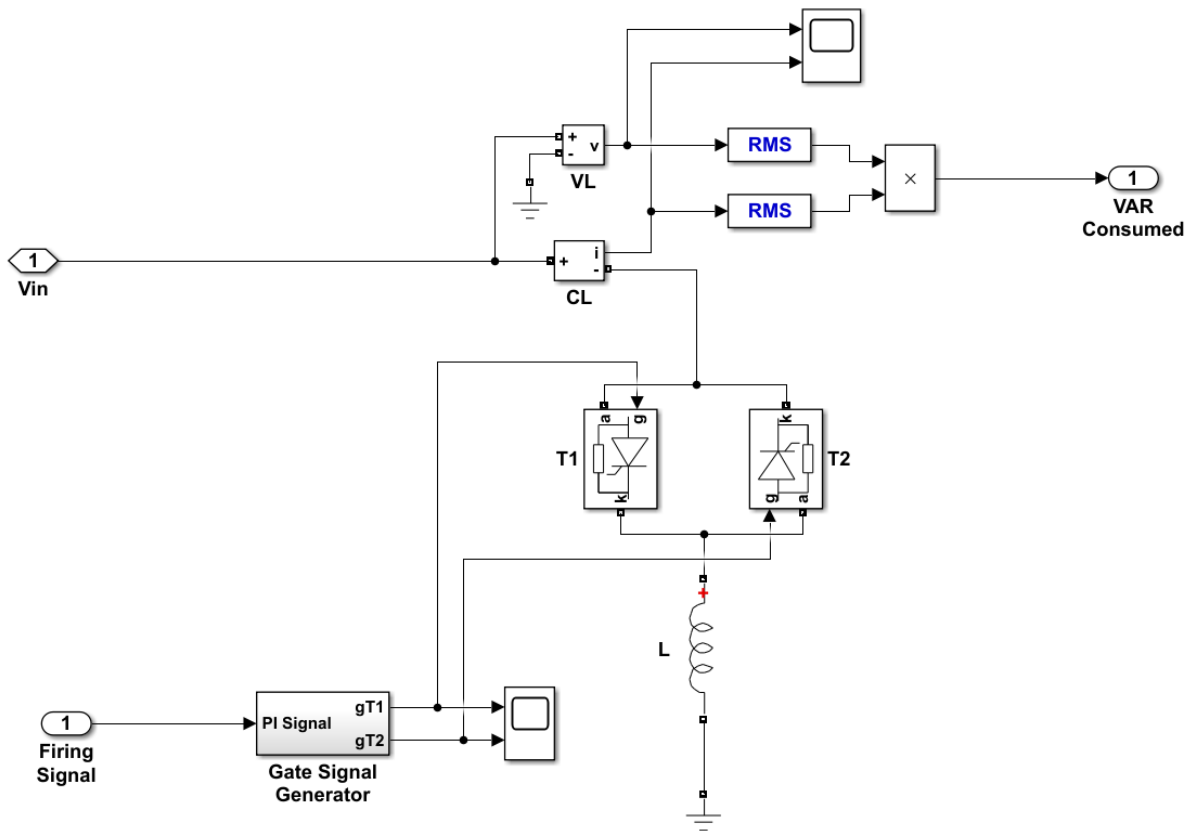

Figure 10: TCR Block

In order to prevent the transients while switching, the voltage across the capacitor ( $V_C$ ) is compared with the system line voltage ( $V_L$ ). Just when  $V_C = V_L$ , the capacitor is switched on.

### 3.4 TCR Block

Figure 10 shows the TCR Block. The firing angles generated for the bidirectional thyristor is used to consume the uncompensated VAR from the capacitor banks with the inductor of size 2.5KVAR. The excess VAR generated by capacitor bank is given as an input to PI controller. PI controller gives command signal to Gate Signal Generator (GSG) circuit. The GSG circuit generates appropriate gate signal to turn ON bidirectional thyristors to consume excess VAR by inductor and thus maintaining the pf of line near about unity.

## 4. Simulation and Results

The MATLAB Simulink software is used for obtaining the simulation results of the designed compensator. The various Simulink output from the scope are shown in

the following figures. In Figure 11, the fine gray middle line represents reactive power consumed or demanded by the loads. The dark bottom line represents the reactive power supplied by the source. And, the very thick topmost dark line represents the reactive power supplied by the capacitor units. The table shown below shows the corresponding reactive power associated with the source, capacitors and the loads.

In Figure 12, the difference between the generated VAR and the required VAR by the loads is consumed by the inductor in TCR branch. For example: for 0-3 seconds time, the difference VAR is  $(4-3) = 1\text{kVAR}$  from Figure 11. This difference is consumed by the inductor coil as shown in Figure 12.

As seen from the simulation results, when load demand VAR it is supplied by the capacitor banks of SVC. The overcompensated VAR is consumed by inductor in TCR branch. The VAR drawn from the source after the installation of SVC is nearly zero. The pf of line is maintained at unity all the time as shown in Figure 13.

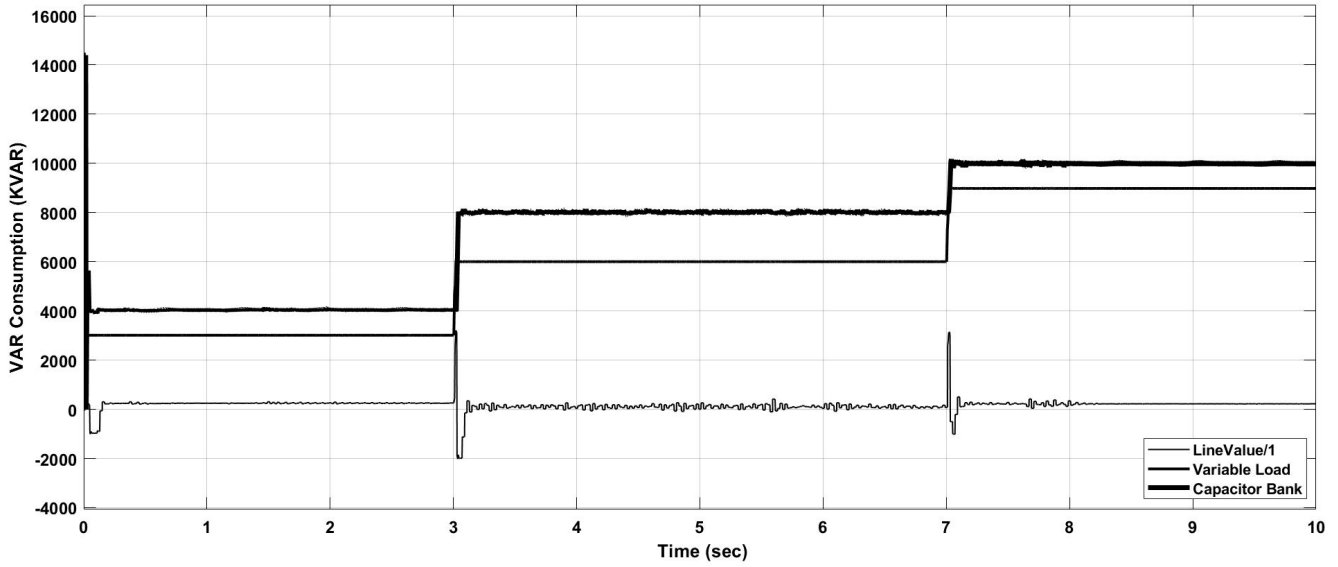

Figure 11: Step change VAR behavior from Load, Capacitor bank and the Source

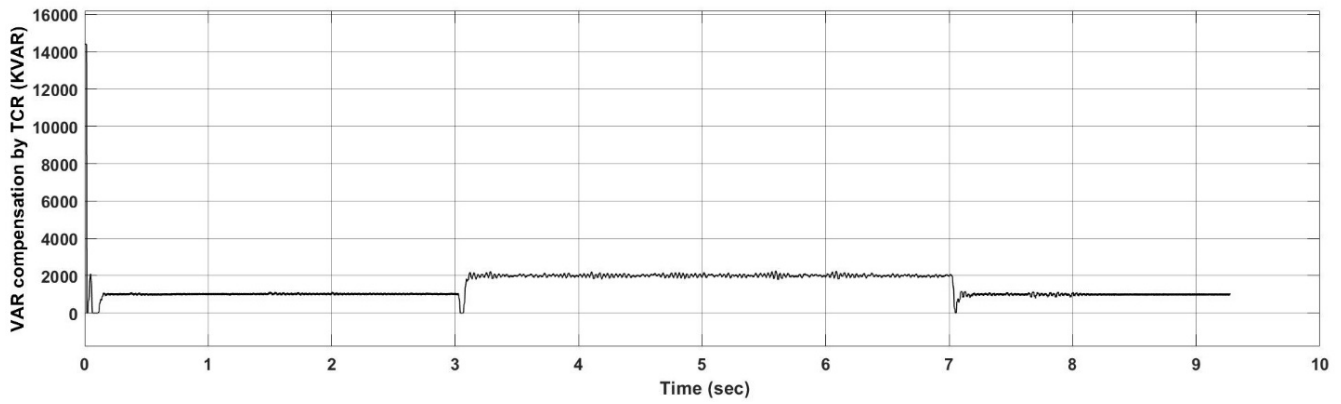

Figure 12: Step change VAR behavior of inductor coil in TCR branch

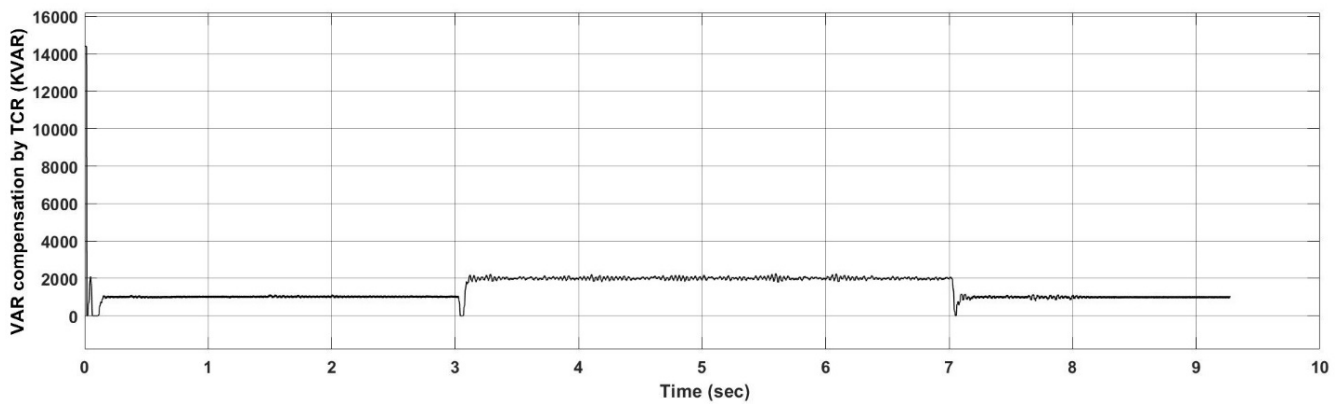

Figure 13: Power Factor of line



## 5. Conclusion

This paper presents how the power system reliability can be enhanced by supplying the reactive power demanded by the inductive loads from the locally installed capacitors (TSC) and not drawing any reactive power from the distant source itself. While doing so, the problem of over-compensation can be avoided by the use of the inductive coil as purely inductive load from the TCR branch. In order to verify this, the experiment was carried out in MATLAB/SIMULINK and the results were as expected: the power factor of the main supply line was always maintained at near about unity despite the use of time-varying inductive loads in the load side.

## References

- [1] H. K. Tyll and F. Schettle, "Historical overview on dynamic reactive power compensation solutions from the begin of ac power transmission towards present applications," in *2009 IEEE/PES Power Systems Conference and Exposition*. IEEE, 2009, pp. 1–7.
- [2] N. G. Hingorani and L. Gyugyi, *Understanding FACTS: concepts and technology of flexible AC transmission systems*. IEEE press, 2000.
- [3] T. J. Miller, "Reactive powercontrol in electric systems, john willey& sons," Inc, New York, 1982.
- [4] R. M. Mathur and R. K. Varma, *Thyristor-based FACTS controllers for electrical transmission systems*. John Wiley & Sons, 2002.
- [5] G. Vishwakarma and N. Saxena, "Enhancement of voltage profile by using fixed capacitor-thyristor controlled reactor (FC-TCR)," *International Journal of Electrical, Electronics and Computer Engineering*, vol. 2, no. 2, pp. 18–22, 2013.
- [6] J. Gutierrez, J. Montano, M. Castilla, and A. Lopez, "Power-quality improvement in reactive power control using fc-ctr circuits," in *IEEE 2002 28th Annual Conference of the Industrial Electronics Society (IECON 02)*, vol. 2. IEEE, 2002, pp. 880–885.
- [7] K. P. Panda, S. Samantaray, and S. Rout, "Prototype design of power factor correction circuit for transmission lines using thyristor switched capacitor scheme," *World Journal of Modelling and Simulation*, vol. 13, no. 4, pp. 314–321, 2017.
- [8] K. C. Taktode, G. S. Rojatkar, B. T. Raut, and M. H. Nerkar, "Reactive power control by using thyristor switched capacitor (TSC) and thyristor controlled reactor (TCR) in FACTS," *International Journal of Science and Research (IJSR)*, 2018.
- [9] M. R. Amin and R. B. Roy, "Design of microcontroller based thyristor controlled three-phase static volt-ampere reactive compensator," in *2014 International Conference on Informatics, Electronics & Vision (ICIEV)*. IEEE, 2014, pp. 1–6.

